

Application Guide EC-Control V 2.0

Part no. 25714-2-0199

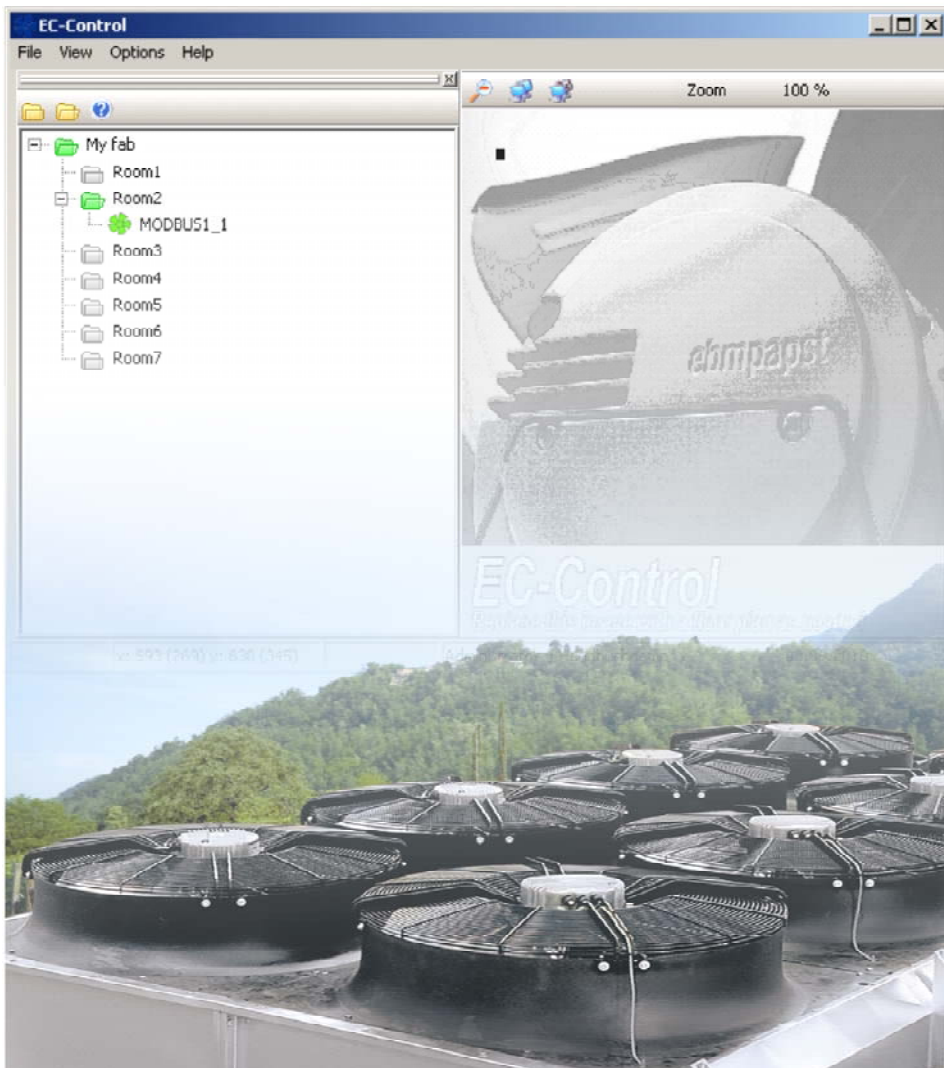

PC control software for bus-compatible fans

Application Guide



The engineer's choice.

ebmpapst

Copyright @ ebm-papst Mulfingen GmbH & Co. KG, 2011

All rights reserved

March 2011

ebm-papst Mulfingen GmbH & Co. KG

Bachmühle 2

74673 Mulfingen

<http://www.ebmpapst.com>

info1@ebmpapst.com

This Application Guide includes some products coming from other manufacturers. In most cases, the product names mentioned as well as the manufacturer names are registered brand names and/or registered trademarks.

Table of content

1.	Safety instructions	3
2.	Basic information and terminology used with EC-Control.....	4
2.1.	Open Loop Control.....	8
2.2.	Closed-Loop Control	8
2.3.	P- and I-factor	9
2.3.1.	Proportional control	10
2.3.2.	PI-control	11
2.4.	Operation modes of EC-Control.....	12
2.5.	Active direction of a control circuit (only for operational mode "Sensor control").....	13
2.6.	Limiting values for speed and PWM signal	15
3.	Setting options and basic functions of MODBUS	17
3.1.	Networking and addressing of MODBUS nodes	17
3.2.	Soft On/Off (Motor Stop enable)	21
3.3.	Switching the parameter set.....	22
3.4.	Fail-safe function.....	23
3.5.	Setting actual value with sensor via ports Ain2 U respectively Ain2 I.....	24
3.6.	Setting actual value with two sensors	25
3.7.	Set value setting via inputs Ain1 U respectively Ain1 I or via EC-Control	26
3.8.	Curves	27
3.8.1.	Input curve.....	27
3.8.2.	Inverse curves	29
3.8.3.	Output curve.....	30
4.	Use of EC-Control in customer applications	31
4.1.	Refrigeration plants.....	31
4.1.1.	Master-Slave configuration (star-shaped)	31
4.1.2.	Master-Slave configuration with cascading mode	36
4.1.3.	Reverse mode to clean and defrost exchanger	38
4.2.	Notes on setting parameters for closed-loop airflow control in air-con units	41
4.2.1.	Digital definition of set values with closed-loop airflow control, e.g. Day/Night mode switch	43
4.2.2.	Analogue definition of set value with closed-loop airflow control.....	45
4.3.	Closed-loop temperature control – Random control curve with temperature sensor.....	47
Index	51

History of changes and modifications

Date	Version	Change / Modification
31.03.2011	1.0	First Application Guide Version, English

1. Safety instructions

Carefully read the User Manual and the Application Guide before starting to work with EC-Control. Disregarding warnings and these instructions may result in malfunction or troubles. Make sure the User Manual is always kept at hand wherever the software is used. When selling the software or passing it on, both the installation instructions and the User Manual are to be passed on as well. For information on potential hazards and how to avoid them, this installation instruction may be copied and passed on.



Handling and operation are subject to national directives on workplace safety.



Electromagnetic radiation may come into play.

Should unacceptable radiation intensities occur once installed, the customer has to provide adequate and appropriate shielding.



Make sure no fan can be switched on accidentally! Switching on is possible if EC- Control is used carelessly. There is a chance of bodily harm, if not fatal accidents, being caused this way! Always operate fans with guard grilles in place and make sure you have taken every conceivable safety precaution.



This software is not designed for use in safety-critical or vital systems!
This software does not support real time use.

Proper use

- Proper use is defined as open-loop control and diagnosis of ebm-papst fans with RS485-based ebmBUS V3 or MODBUS with ebm-papst standard profile.

Improper use

- Operating the interface converter on interfaces not intended for such use
- Operating interface converters at higher voltages than specified in their instructions
- Using interface converter cables in an improper way and not as specified
- Operation in extremely humid environments (heavy rain or intense humidity)
- Operation in explosive environments
- Putting fans into operation via software without their safety features being active
- Deactivating of safety features of the fan firmware by setting improper parameters
- Using the software in safety-critical or vital systems

2. Basic information and terminology used with EC-Control

EC-Control allows ebmBUS und MODBUS fan networks to be visualised and parameterised.

EC-Control especially facilitates the following activities:

- Setting of fan parameters such as operation mode, set value and control parameters
- Changing the fan address
- Readout of fan parameters such as actual speed, serial number and production date
- Readout of failure status as well as failure memory
- Monitoring of plants, including the option to report failures via e-mail
- Managing a number of plants within one programme installation, useful for service technicians
- Supporting RS232/RS485 and Ethernet/RS485 interface converters
- Simultaneous monitoring of plant parts based on ebmBUS und MODBUS (requiring at least two interface converters)

This Application Guide is a document supplementing the manual. It contains practical examples to help you to make full use of the entire functional scope of EC-Control V 2.0.

Note: This Application Guide uses screenshots of EC-Control V 2.0 Beta 13-16. Illustrations of EC-Control may therefore differ from your version. We also used a fan with MODBUS Protocol version V3.02 (version 01.09.2010). Devices using older firmware do not offer all functions.

What does EC-Control V 2.0 look like? The programme has the following structure:

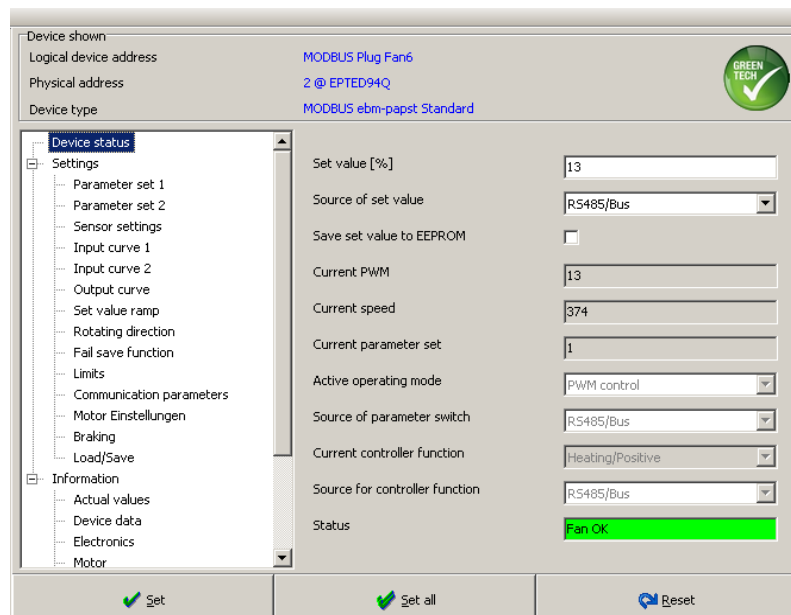

Illustration 1: Overview EC-Control

EC-Control V 2.0

- The structure of EC-Control V 2.0 consists of three major items:
 - Overview
 - Settings
 - Information
- Application Guide describes the possibilities the user is offered in the categories Overview and Settings.

The table below is an overview of the different menu items with their sub-items.

Menu item <i>Settings</i>	Sub-items	Short description
Parameter set 1 respectively parameter set 2	<ul style="list-style-type: none"> • Current parameter set • Parameter set • Operating mode • Min PWM [%] • Max PWM [%] • Motor Stop Enable • Controller function • P-factor [%] • I-factor [%] 	Two sets of parameters allow the user to change the settings easily; you may select operating mode or active controller function, among others.
Sensor settings	<ul style="list-style-type: none"> • Min sensor value • Max sensor value • Sensor unit • Source for controller function • Controller function 	Settings for actual value parameters through sensor, only relevant in operating mode <i>closed-loop sensor control</i>
Input curve 1 respectively Input curve 2	<ul style="list-style-type: none"> • Input curve X1 • Input curve X2 • Input curve Y1 • Input curve Y2 	The input curve determines which set value is to be reached with which input quantity (current/voltage)
Output curve	<ul style="list-style-type: none"> • Function of analogue output • Output curve X1 [%] • Output curve X2 [%] • Output curve Y1 [V] • Output curve Y2 [V] 	The terminal strip of the ebm-papst units has a 0-10V output to connect further units. This 0-10V output can be assigned to either the PWM phase control factor 0-100% or rpm.
Set value ramp	<ul style="list-style-type: none"> • Ramp up time [s] • Ramp down time [s] 	The set value ramp defines the time needed by the fan to reach full speed. Shortening this time results in the motor having a higher running noise.
Direction of rotation	<ul style="list-style-type: none"> • Source of rotating direction 	Here, the direction of rotation can be changed temporarily.
Fail-safe function	<ul style="list-style-type: none"> • Fail-safe speed • Set value fail-safe speed • Time lag fail-safe speed 	With cable break (set value input), the motor keeps running at a set fail-safe operation speed.
Limits	<ul style="list-style-type: none"> • Maximum speed [rpm] • Maximum permitted speed [rpm] • Minimum permitted PWM • Maximum permitted PWM • Start PWM [%] 	Here, the maximum speed can be set and other limiting values are displayed
Communication parameters		Here, the device address can be

	<ul style="list-style-type: none"> • Device address 	changed. MODBUS devices have the address 1 as per delivery status.
Motor settings	<ul style="list-style-type: none"> • Speed limit [rpm] 	This is the unchangeable limit speed of the motor
Braking	<ul style="list-style-type: none"> • Braking speed [rpm] • Braking angle 1 [°] • Braking angle 2 [°] 	Here, the braking speed and braking angle is displayed; nothing can be changed, this is for your information only.
Load / Save	<ul style="list-style-type: none"> • Load OEM data • Save data in OEM • Activate factory settings 	Depending on authorisations, configurations can be saved respectively loaded.

The terminal strip of an ebm-papst MODBUS device has the following design. Depending on size and production date, you may notice differences:

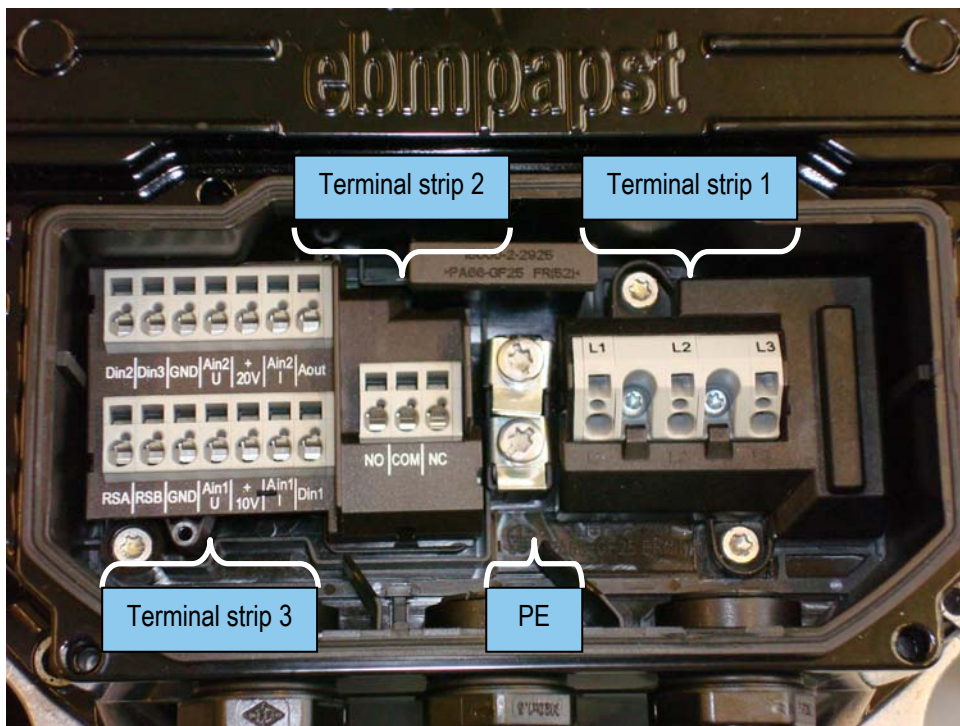

Illustration 2: Terminal strip of an ebm-papst MODBUS device

Description of the MODBUS terminal strip:

Terminals		Designation	Description
KL1	1	L1	Mains supply
	2	L2	
	3	L3	
PE		PE	PE conductor
KL2	1	NC	Status relay
	2	COM	Status relay
	3	NO	Status relay
KL3	1	RSA	Bus terminal
	2	RSB	Bus terminal
	3	GND	Ground
	4	Ain1 U	Analogue input 1 (set value)
	5	+10V	Auxiliary voltage +10 VDC
	6	Ain1 I	Analogue input 1 (set value)
	7	Din1	Digital input 1
	8	Din2	Digital input 2
	9	Din3	Digital input 3
	10	GND	Ground
	11	Ain2 U	Analogue input 2 (actual value)
	12	+20V	Auxiliary voltage +20 VDC
	13	Ain2 I	Analogue input 2 (actual value)
	14	Aout	Analogue output

2.1. Open Loop Control

Open loop control is an open functional chain in which the input variable influences the output variable, but not vice versa (see Illustration 3). The aim is to correctly choose the actuating variable y to bring the output variable x (actual value) to the desired reference input variable w (set value). There is no comparison between set value and actual value, and no correction of the actuating value resulting from such a comparison. Potential interfering factors are not compensated.

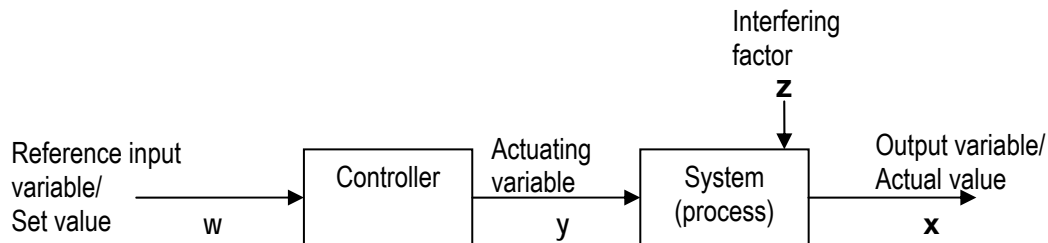

Illustration 3: Block diagram of an open loop control

Open loop with 0-10V / PWM controlled fan (Illustration 4):

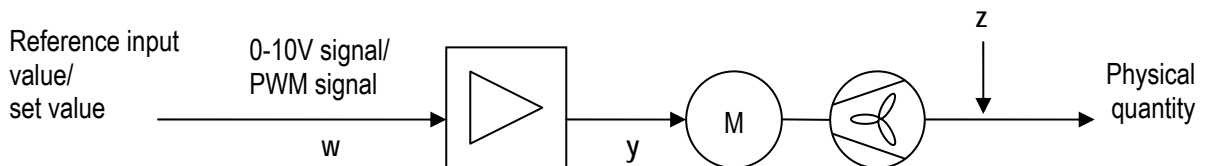

Illustration 4: Open loop control ebm-papst

2.2. Closed-Loop Control

With a closed-loop control, the actual value x is collected and compared with the set value w via a measuring device as feedback variable r (see illustration 5). In the comparing element, these values are taken to form the error variable e . This error variable is also known as control deviation. It is the difference between set value and feedback variable and is constantly recalculated, as the controlled section is permanently influenced by potentially interfering factors z . In contrast to the open loop control described above, a closed-loop control can compensate any such occurring interference thanks to this feedback and can thus align the control variable x with the set process.

For Illustration 5 and illustration 6, the following definitions apply:

w	Reference input variable (set value)
e	Control difference
u	Controller output variable
y	Actuating variable
z	Interfering factor
x	Control variable (actual value)
r	Feedback variable

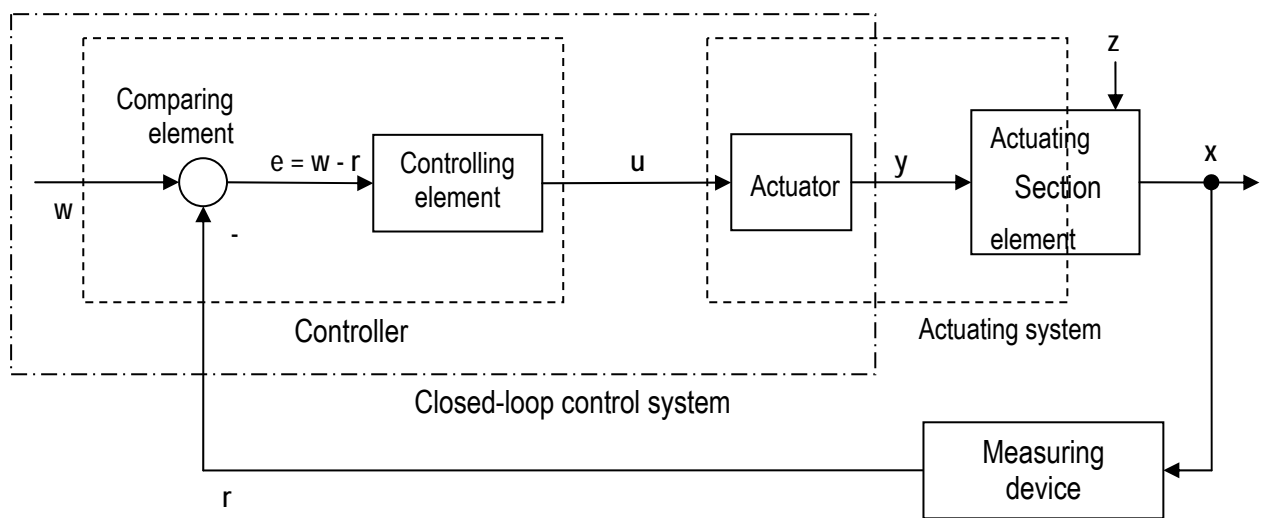

Illustration 5: Block diagram of a closed-loop control

Generally, there is no differentiation between closed-loop controller output variable u and actuating variable y ; rather, they are jointly referred to as actuating variable y . The impact of the measuring device is also often ignored, and so the feedback variable r is often referred to as the control variable (actual value) x .

Thus, we get a simplified control-loop:

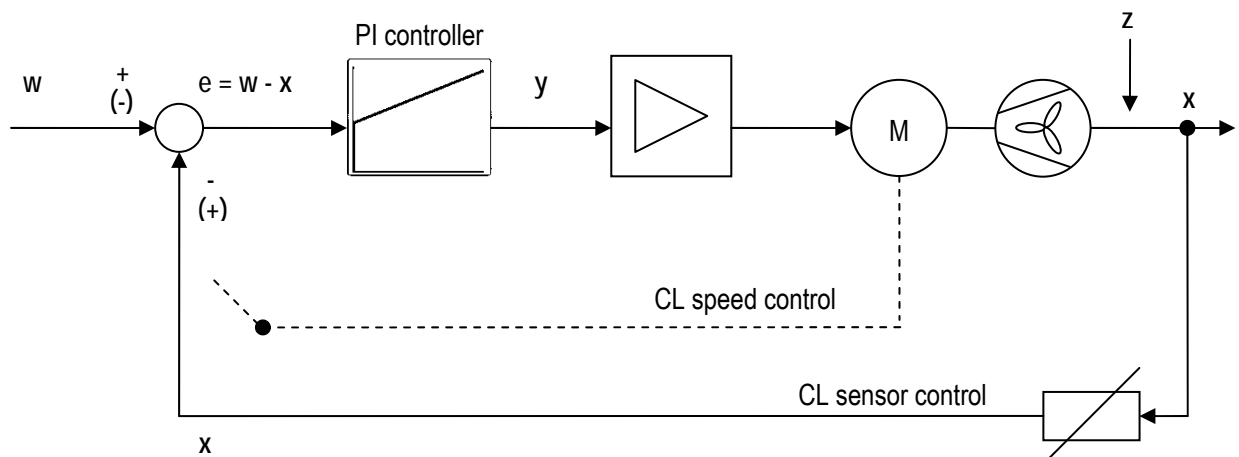

Illustration 6: Closed Loop control ebm-papst

Typical measuring devices for fans are pressure, airflow and temperature sensors.

The set value w can be set in analogue or digital way using EC-Control software for setting it. A PI controller is tasked with compensating for the system deviation and achieving set value = actual value.

2.3. P- and I-factor

Ideally, the deviation between set and actual value with a closed-loop control is zero (remaining control difference $e(t)=0$ for $t \rightarrow \infty$). Is there a difference with the closed-loop control as illustrated above, the actual value becomes adjusted. The proportional band (P-contribution) and the integral time (I-contribution) of the PI-controller determine how precisely and how quickly this adjustment is effected

2.3.1. Proportional control

If the I-contribution of a PI-controller is zero, we speak of a pure P-control. A P-controller works like an amplifier for the control difference e . To understand how the P-factor is calculated in EC-Control, have a look at Illustration 7.

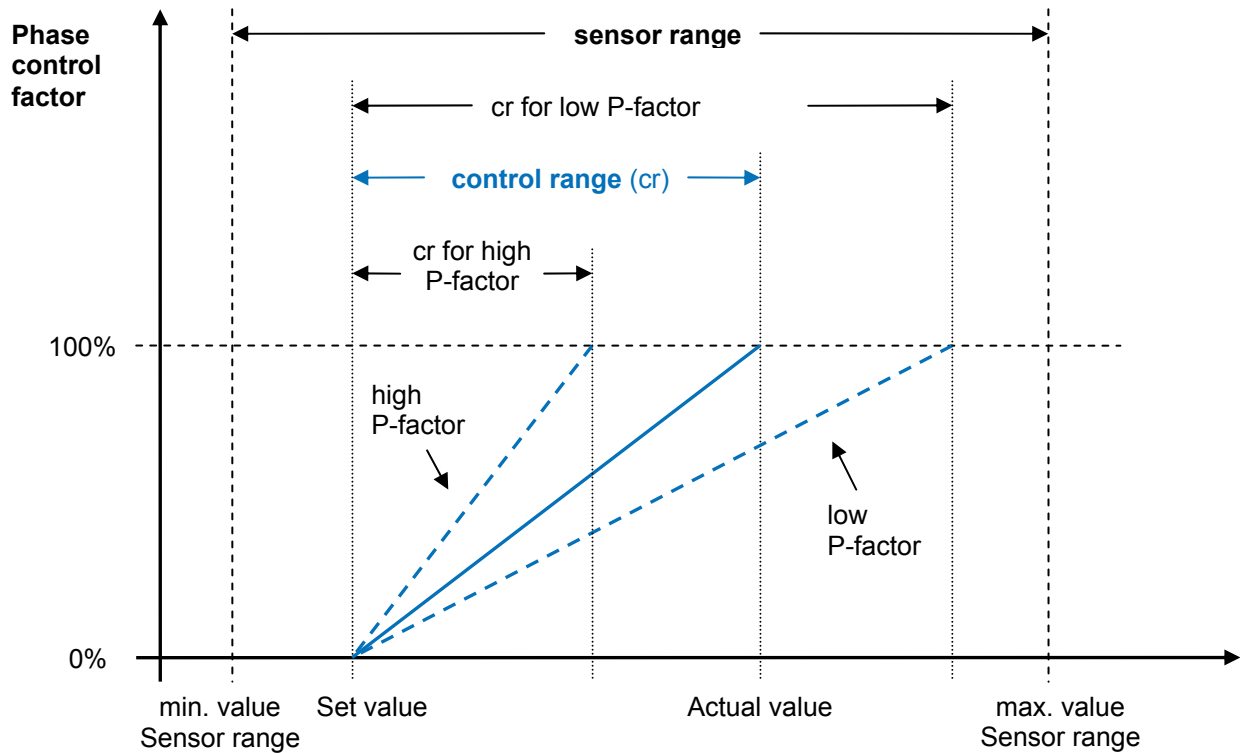

Illustration 7: P-factor

The actual value is established using a sensor. The sensor itself is limited by its minimum and maximum value, also known as the “sensor range”. This range can either be defined by the sensor itself or manually changed in EC-Control.

The desired set value is defined analogically (terminal Ain1 U or Ain1 I) or digitally via EC-Control. The difference between the actual value and the set value, which results in a phase control factor of the motor of 100%, is referred to as the control range. Control range and P-factor are dependent on each other. They are different representations of the same value. Using sensor range and control range, the P-factor can be calculated.

$$P \text{ Factor} = \frac{(Max - Min)}{control \ range} \times 100\% = \frac{sensor \ range}{control \ range} \times 100\% \quad (1)$$

The P-factor can be entered via EC-Control. It is generally accepted that:

- Too high a P-factor may result in continuous oscillations of the closed-loop control.
- Too low a P-factor will result in permanent control deviation, and the set value is never reached exactly.

Using the P-factor, the P-contribution (contribution to absolute deviation) can be calculated. The control deviation e here is the difference between the defined set value and the current actual value which is constantly updated by the sensor.

$$P \text{ contribution} = P \text{ factor} \times \frac{\text{Control difference } e(t)}{\text{sensor range}} \quad (2)$$

Incorporating equation (1) in (2), you get:

$$P \text{ contribution} = \frac{\text{sensor range}}{\text{control range}} \times 100\% \times \frac{\text{Control difference } e(t)}{\text{sensor range}} = \frac{\text{Control difference } e(t)}{\text{control range}} \times 100\% \quad (3)$$

If $\text{Control difference } e(t) \geq \text{control range}$, the motor runs at a maximum phase control factor of 100%. If control difference is below the set control range, the phase control factor decreases.

2.3.2. PI-control

Instead of the P-controller with purely proportional contribution, we now have a look at a PI-controller with additional integral contribution (contribution of the sum of all deviations).

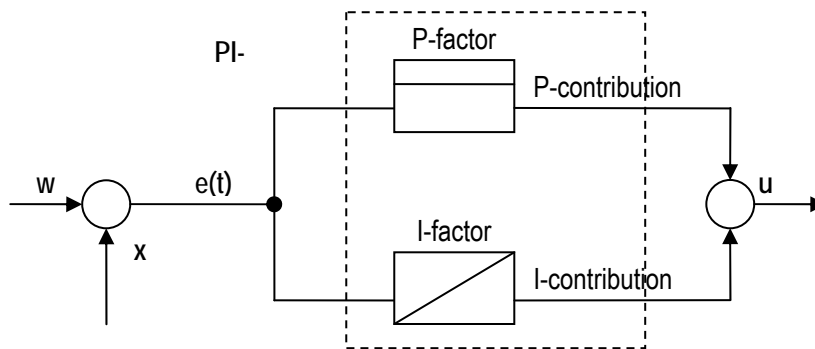

Illustration 8: PI-controller

We talk of a controller with proportionally integrating effect. The controller output variable u is made up of the sum of the P-contribution and the I-contribution, with the I-contribution trying to keep the control deviation at zero in the timely weighted average.

$$\text{Controller output} = P \text{ contribution} + I \text{ contribution} \quad (4)$$

How to calculate the P-contribution is already known. I-contribution is calculated as follows:

$$\Delta I \text{ contribution} = I \text{ factor} \times \frac{P \text{ factor}}{100\%} \times \frac{\text{control difference } e(t)}{\text{sensor range}} \quad (5)$$

The I-factor here is the value as entered by the user in EC-Control. Adding up the difference of the I-contribution per sampling instance across a certain range, you get the following equation allowing you to calculate the controller output:

$$\text{Controller output } (t) = P \text{ contribution } (t) + \sum_{i=0}^t \Delta I \text{ contribution } (i) \quad (6)$$

Using equations (2) and (5) for P- and I-contribution, we thus get:

$$\text{Controller output } (t) = P \text{ factor} \times \frac{e(t)}{\text{sensor range}} + \sum_{i=0}^t I \text{ factor} \times \frac{P \text{ factor}}{100\%} \times \frac{e(t)}{\text{sensor range}} \quad (7)$$

To arrive at the sort of representation we know from automatic control engineering, the equation needs to be rearranged:

$$\text{Controller output } (t) = \frac{P \text{ factor}}{\text{sensor range}} \times e(t) + \frac{P \text{ factor}}{\text{sensor range}} \times \frac{I \text{ factor}}{100\%} \sum_{i=0}^t e(t) \quad (8)$$

$$\text{Controller output } (t) = \frac{P \text{ Faktor}}{\text{sensor range}} \left(e(t) + \frac{I \text{ Faktor}}{100\%} \sum_{i=0}^t e(t) \right) \quad (9)$$

Using the proportional coefficient

$$k_p = \frac{P \text{ factor}}{\text{sensor range}} \quad (10)$$

and the ratio between sampling time T_a and reset time T_n

$$\frac{T_a}{T_n} = \frac{I \text{ factor}}{100\%} \quad (11)$$

equation (10) and (11) yield the conventional equation (12) of a PI-controller:

$$\text{Controller output } (t) = k_p \left(e(t) + \frac{T_a}{T_n} \sum_{i=0}^t e(t) \right) \quad (12)$$

With ebm-papst, sampling time T_a is 50ms, so for the I-factor, we get this equation (13):

$$I \text{ factor} = \frac{50\text{ms}}{T_n} \times 100\% \quad (13)$$

The generally known form of representation is:

$$\text{Controller output } (t) = k_p \left(e(t) + \frac{1}{T_n} \int_0^t e(t) dt \right) \quad (14)$$

2.4. Operation modes of EC-Control

EC-Control works with three possible operation modes. The mode of operation can be selected in EC-Control V 2.0 by going to Parameter set.

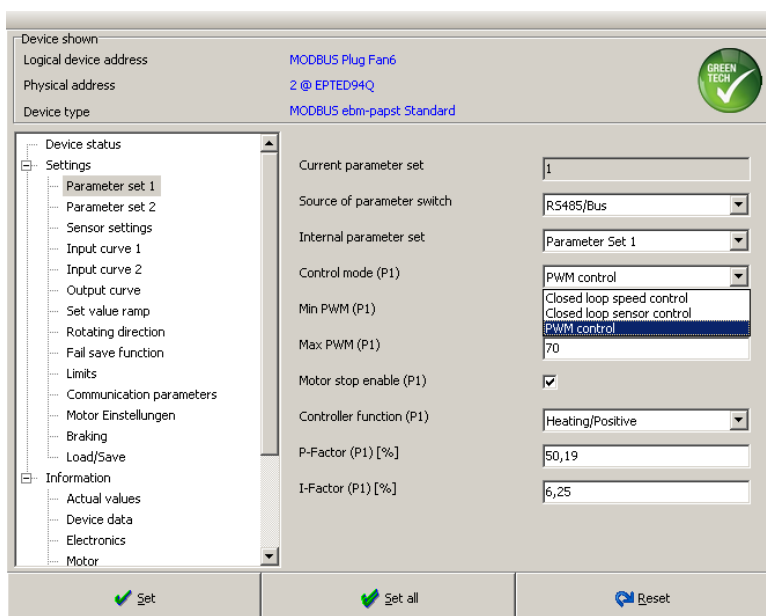

Modes of operation

- Electing the mode of operation is decisive for many other and further functions.
- Modes of operation can be allocated to the two parameter sets P1 and P2 independently from each other.

Illustration 9: Modes of operation

■ Closed-loop sensor control

The sensor collects the actual value in the form of temperature, pressure or airflow. The set value is provided using the same unit. In case there is a control difference between set and actual value, the fan tries to minimise it despite any potential interfering factors.

■ Closed-loop speed control

Set and actual values are directly given as speed using revolutions per minute [rpm]. Current speed is established by electronics, and the controller adjusts it in accordance with the set value. The fan tries to compensate for any interference respectively change in load in order to keep its speed constant.

■ PWM control (open loop)

Purely an open loop control. This mode of operation has no feedback, which might be necessary to compensate for any occurring interference. P- and I-factor do not apply here.

2.5. Active direction of a control circuit (only for operational mode "Sensor control")

The Closed-loop sensor control mode of operation gives the user the option to switch the active controller function. This function is not relevant for the two other modes of operation. As shown in Illustration 10, when switching the active controller function, the set value and the actual value are inverted (Cooling/Negative) and thus the resulting control difference is changed. Below, there is no differentiation made between feedback variable r and set value x .

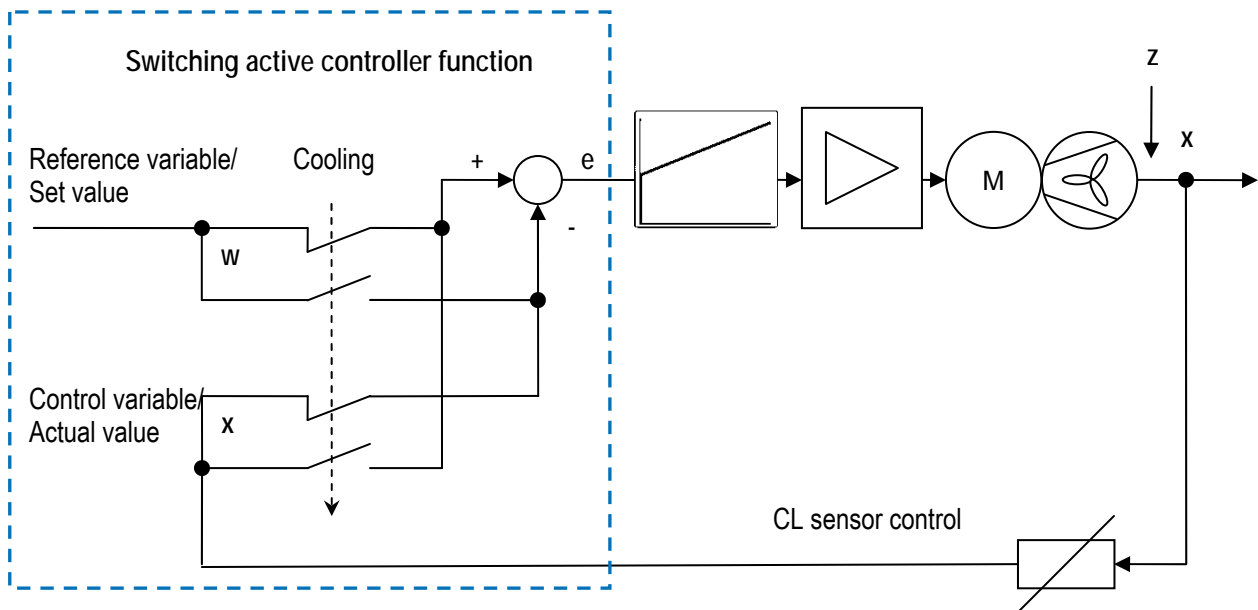

Illustration 10: Switching active direction

In EC-Control, the active controller function is referred to as Heating and Cooling. Generally, we say:

With positive active controller function (“heating”), the rule is:	Control difference = Set – Actual value
With negative active controller function (“cooling”), the rule is:	Control difference = Actual – Set value

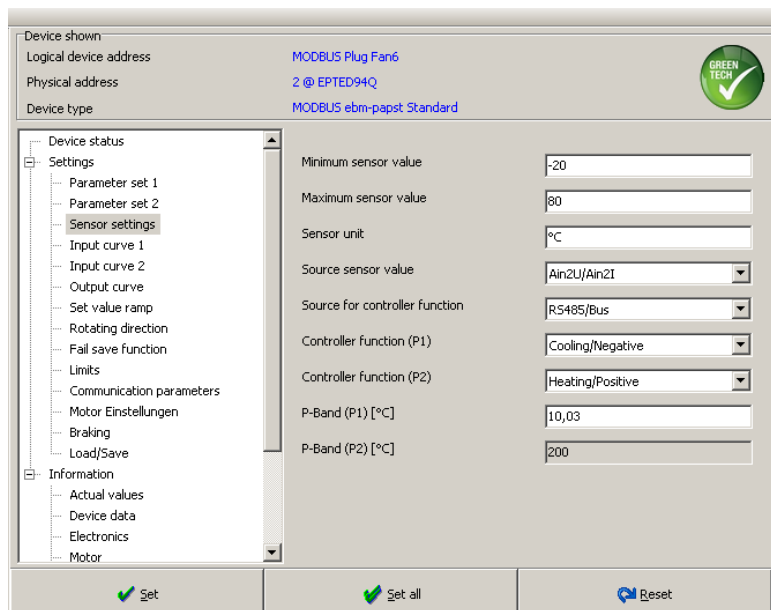

Illustration 11: Active direction

Controller function

Heating/positive resp. Cooling/negative

- Controller function decides on the algebraic sign when calculating the control difference
- Controller function only relevant for Sensor control
- Can be set for both sets of parameters
- The terms Heating and Cooling are actually also used with pressure control and airflow control.

The active controller function, however, has no impact on the direction the motor rotates; it solely plays a role in calculating the control difference.

The switch in active controller function becomes a lot easier to understand by looking at the x-axis in illustration 12. Normally, you use the term Cooling/Negative whenever Actual value > Set value. The term Heating/Positive, however, is used whenever Set value > Actual value.

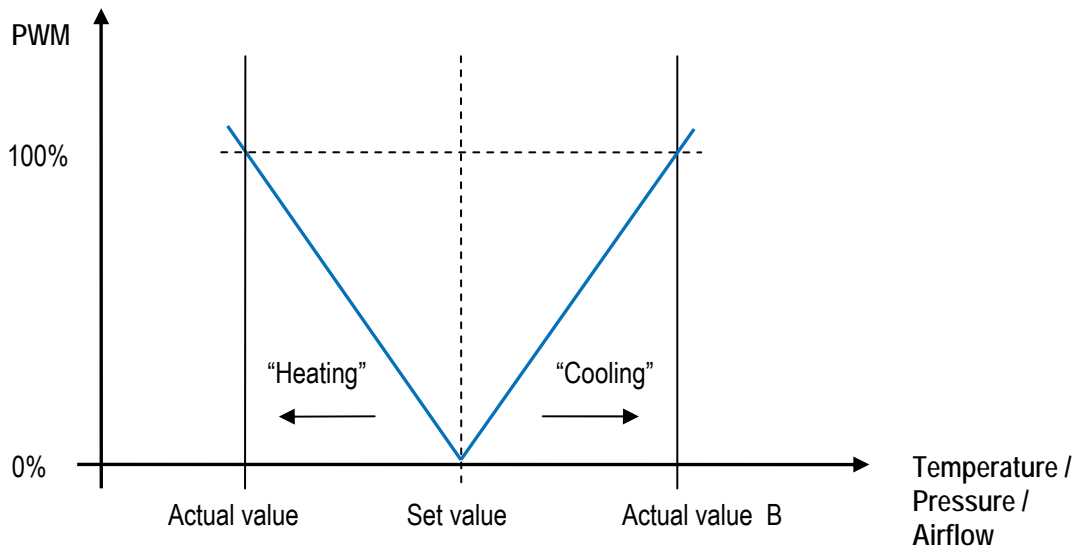

Illustration 12: Heating / Cooling

2.6. Limiting values for speed and PWM signal

In EC-Control V 2.0, there is a subcategory *Limits* in *Settings*. Here, it is possible to limit speed yourself and to display the limiting values as set by ebm-papst.

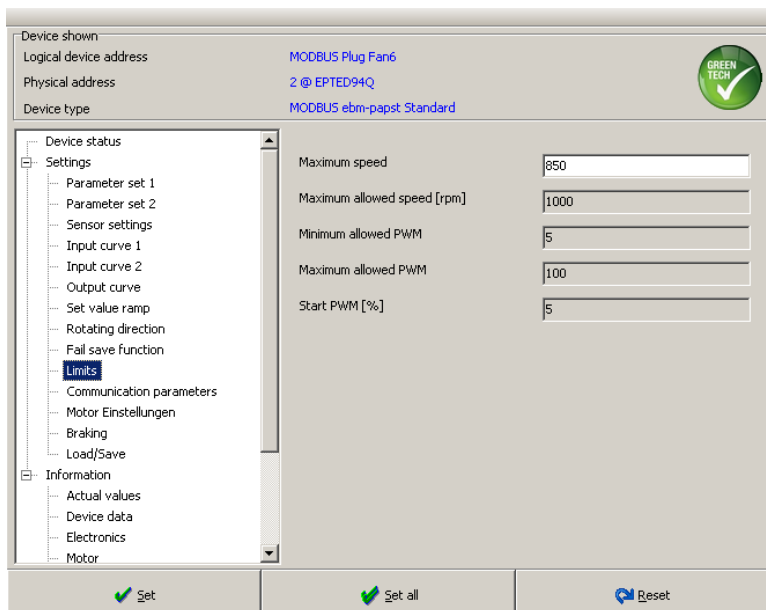

Illustration 13: Limiting values

Limiting values

- Maximum speed can be written by customer
- Remaining limiting values can only be written by ebm-papst, customer write-in is not enabled

For limiting speed, the following two terms are used:

<u>Maximum allowed speed</u>	Permissible speed limit as set by ebm-papst, user write-in is not enabled
<u>Maximum speed</u>	User can limit the speed within the permissible range himself.

Therefore, the following rule applies at all times:

$$\underline{\text{Maximum permissible speed}} \geq \underline{\text{Maximum speed}}$$

Maximum speed in operational mode Speed control gives the speed value for 10V input voltage (20mA input current) and is only used for purposes of scale.

The other three limiting values can also not be changed with the normal level of customer authorisation. Start PWM [%] is the value at which the motor starts rotating. It is always higher than the “minimum allowed PWM” and it is used to overcome the initial breakaway torque.

For PWM-Signal, customer-specific limiting values can be defined. However, Min PWM [%] and Max PWM [%] are not found under subcategory Limits, but under Parameter set (see Illustration 14). The fan operates within the PWM control limits thus defined.

Minimum allowed PWM ≤ Min. PWM ≤ permissible phase control factor ≤ Max. PWM ≤ Max. allowed PWM

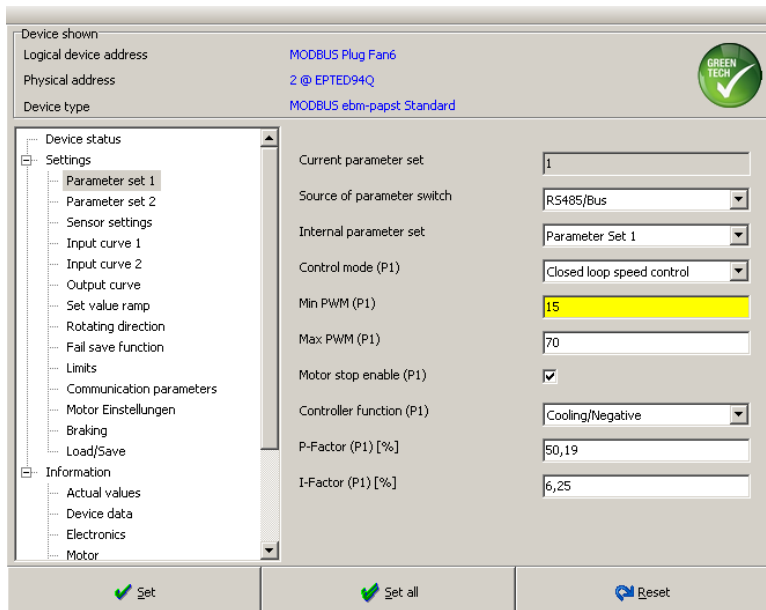

Min/Max PWM

- Here: PWM limited by user: 15-70% PWM signal
- Limiting values by ebm-papst (Illustration 13): 5-100% PWM signal

Illustration 14: Minimal and maximal PWM signal

3. Setting options and basic functions of MODBUS

3.1. Networking and addressing of MODBUS nodes

In order to have the fans operate smoothly on a network, the devices have to be correctly addressed. Some basic principles need to be borne in mind:

- Addresses within a MODBUS segment have to be unique and unambiguous
- Each address may only exist once. There may be no double assignment.
- Factory setting of the fans is address 1
- The first installation step is to re-address the fans (replacing 1).

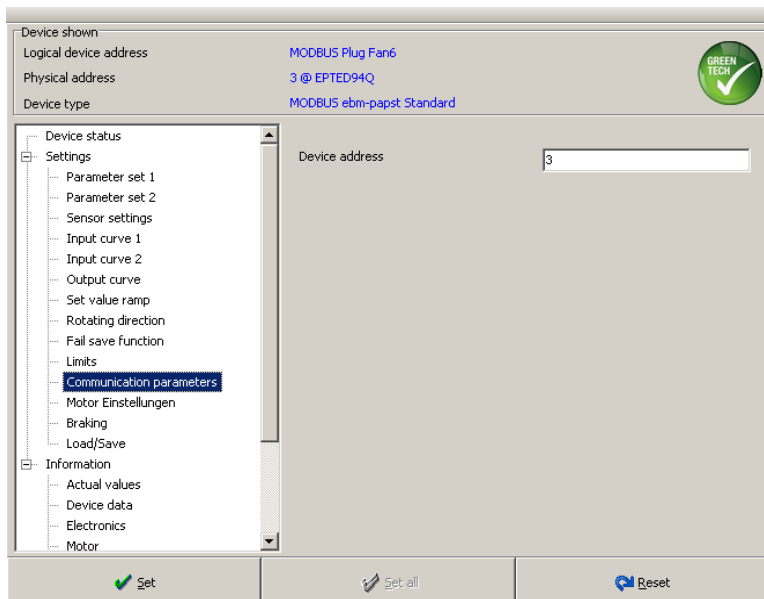

Illustration 15: Device address

Device address

- Keep address 1 free
- When replacing a defect device, a new device with the preset address 1 can be re-addressed in the network.

With MODBUS-RTU, an address range of 1-247 is provided for. When networking, however, it is - by definition - possible to handle four (4) communication paths, respectively subnets, in parallel. The address range of a subnet can thus be multiplied. The subnets are defined via the interface converter and are named accordingly. As shown in the example below, the communication path is integral part of the address.

Subnets respectively communication paths:

- RS232 / RS 485 1...247
- Ethernet / RS485 1...247
- Bluetooth / RS485 1...247

Would result in the following physical addresses:

- 1...247@RS232_Converter_1
- 1...247@Ethernet_Converter_2
- 1...247@Bluetooth_Converter_3

Networking the MODBUS members is shown in Illustration 16 und in Illustration 17 (see pages 19/20).

The connection diagram in Illustration 16 contains the following features:

- *Simple Twisted Pair cable*
ebm-papst recommends using a simple Twisted Pair cable. A Twisted Pair cable is a cable that has the wires of a pair of wires twisted around each other. Due to this twisting, such cables offer protection against symmetric disturbances.
- *Common line*
Implementing a common data line is explicitly recommended in the MODBUS specification in order to counter transmission problems. The GND potentials of the interface modules are linked, and so all controls have the same common reference potential (ground).
- *Line termination (line termination resistors)*
In the connection diagrams at the bottom, the common line is additionally equipped with line terminations (LT) in the form of resistors in order to minimise the reflections at the line ends and thus to get a better signal quality. Line termination resistors are placed at the beginning and end of the bus between D0 (RSB) and D1 (RSA). However, no more than two resistors – 1xLT each at the beginning and 1x LT each at the end of the line each – may be installed. We recommend 120Ω LT resistors with a capacity of 0.5W each.

The connection diagram in Illustration 17 contains the following features:

- *Shielded Twisted Pair cable*
For use in interference-prone areas, MODBUS.org recommends using shielded Twisted Pair cables. Their shield is made of aluminium foil or copper-mesh and prevents impacts from electromagnetic fields.
- *Common line*
See above
- *Line termination (line termination resistors)*
See above

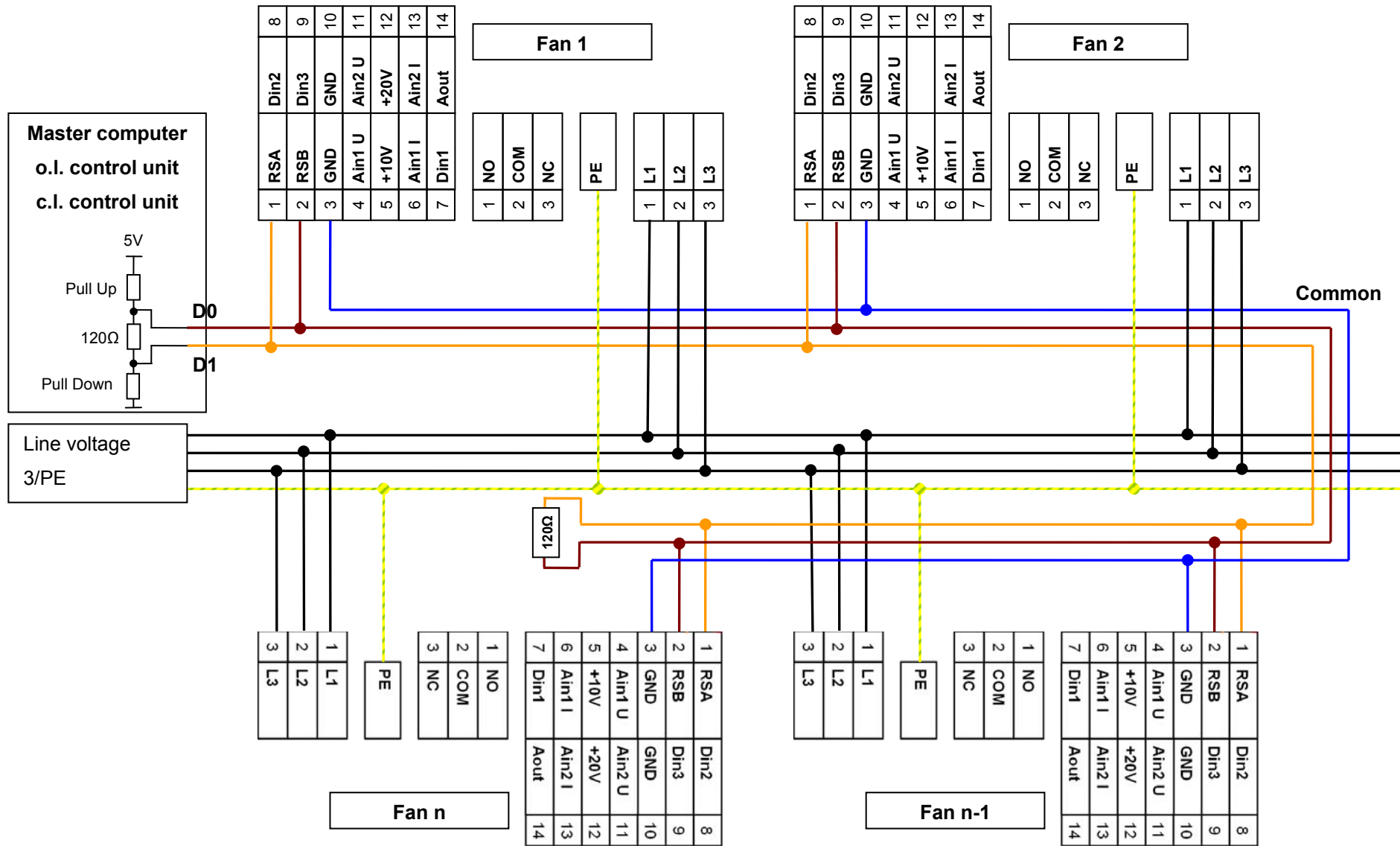

Illustration 16: Connecting a number of devices to MODBUS via Twisted Pair cables with 2 wire pairs

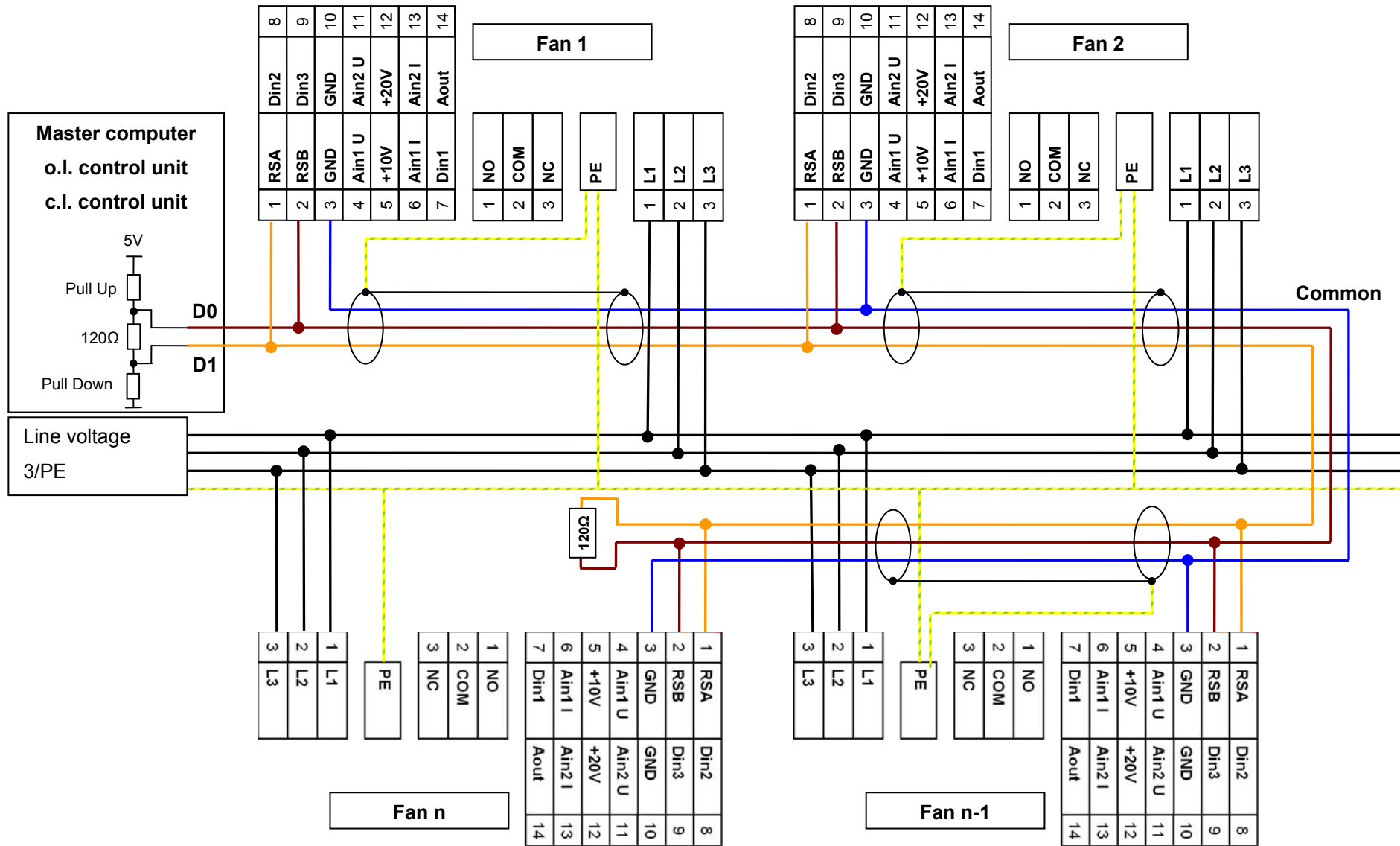
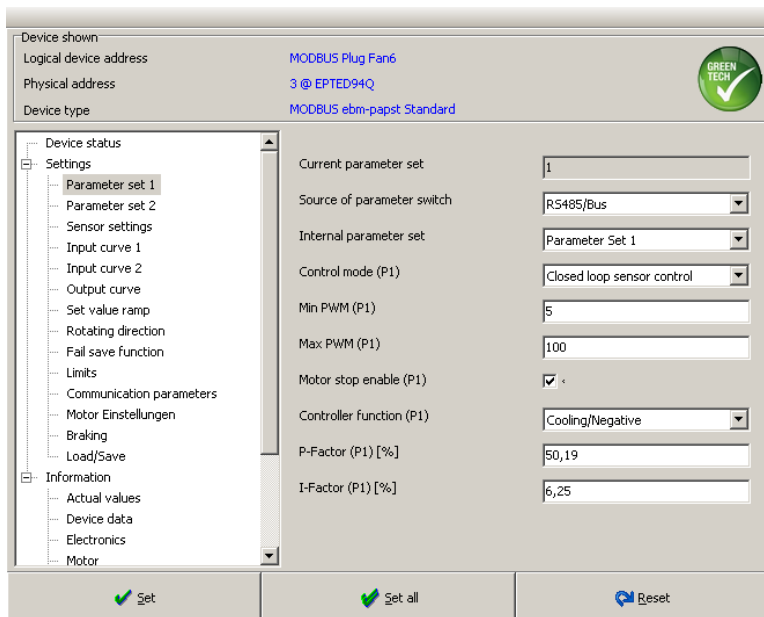

Illustration 17: Connecting a number of devices to MODBUS via shielded Twisted Pair cables with 2 wire pairs

3.2. Soft On/Off (Motor Stop enable)

Constantly switching EC motors on and off via mains is additional stress for the electronic components and shortens their service life. To avoid this, ebm-papst EC motors have an On/Off function to bring the motor softly to a standstill. Using EC-Control, you can stop the motor despite ebm-papst having pre-set a minimally permissible PWM signal (see 2.6).

The function *Motor stop enable* can be found under the sub-item *Parameter set*. This has to be activated to switch off the motor softly.



Motor Stop enable

- *Motor stop enable* must be activated to bring the motor to a standstill softly.
- If the function is deactivated, the motor always runs at least with the pre- *Min PWM* value.

Illustration 18: Motor Stop Enable

- *Operation mode Closed-loop speed control or Open-loop PWM control*
If *Motor stop enable* is activated, entering the set value 0 (rpm=0 U/min or PWM signal=0%, depending on the operation mode) sets the motor rpm to zero.
- *Operation mode Closed-loop sensor control*
If the actual value falls below or exceeds the set value (depending on the active direction), the motor is brought to a standstill on condition that *Motor stop enable* is active.

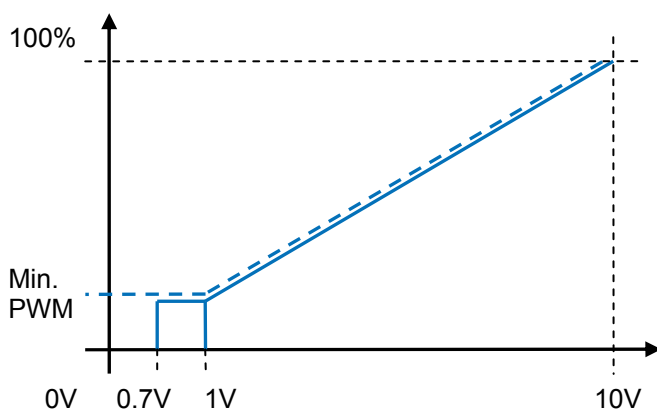

- *Motor stop enable* activated (solid line):
Motor stops with signal < 0.7V
- *Motor stop enable* deactivated (interrupted line):
Motor runs at minimum PWM-signal
- Hysteresis: Motor starts at a voltage of 1V, but only stops with 0.7V (if *Motor stop enable* is activated)

Illustration 19: Motor stop enable

3.3. Switching the parameter set

MODBUS offers the possibility to save two parameter sets. By selecting the parameter set, different preset options are possible. Each of the two sets of parameters contains the following setting options:

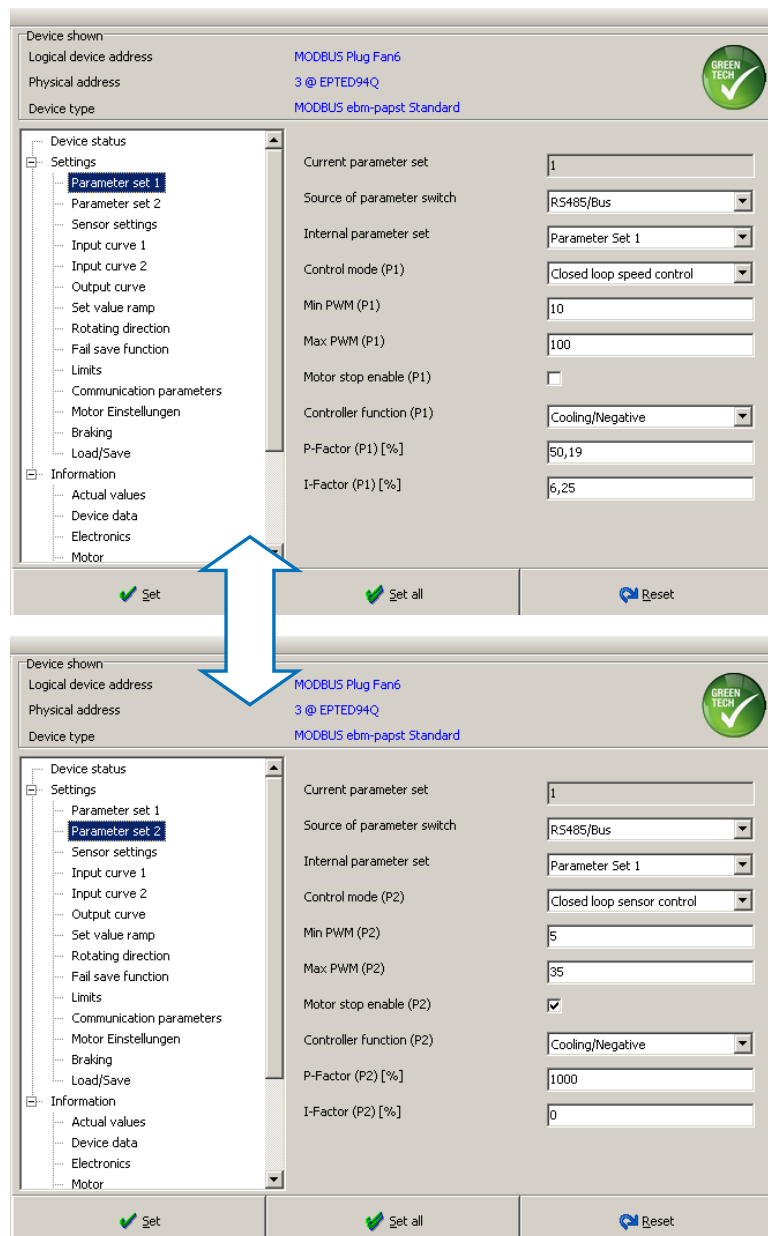

Illustration 20: Parameter set 1 and parameter set 2

If, therefore, Clamp Din2 respectively Clamp Din3 is selected as Source of parameter switch, switching parameter sets via EC-Control is no longer possible.

- Parameter set 1 is selected whenever Din2 (respectively Din3) is open or if there is a voltage of >5V.
- Parameter set 2 can be selected by bridging Din2 (respectively Din3) with GND.

While the setting options mentioned above can be found in sub-category Parameter set, the set value can be entered only by going to Device status!

Parameter sets P1/P2

Explanation of the parameters

■ Source of parameter switch

RS485/Bus corresponds to switching via EC-Control, Terminal Din2 corresponds with switching via digital input Din2 of the terminal strip.

■ Internal parameter set

If the source of the parameter set is set to RS485/Bus, EC-Control allows you to switch between parameter set 1 and parameter set 2.

■ Control mode

The control mode can be selected for each parameter set independently from each other (see 2.4).

■ Min PWM resp. Max PWM

The limits of the phase control factor the motor works with (see 2.6).

■ Motor stop enable

If this function is enabled, the motor can be stopped (see 3.2).

■ Controller function (see 2.5)

■ P-Factor / I-Factor

Here, the closed-loop control parameters P-Factor respectively I-Factor can be entered. Their values have an impact on the closed-loop control mode in the operation modes Closed-loop sensor control and Closed-loop speed control (see 2.3).

In order to store a set value for each parameter set, the following settings have to be decided on one by one and in their proper sequence. In doing so, it is important to activate the set point by clicking Set as soon as each step is completed.

Illustration 21: Save set value to EEPROM

Saving set value

For both parameter sets

- Under Parameter set 1, activate parameter set 1
- Under Overview, activate function Save set value to EEPROM and enter set value.
- Under Parameter set 2, activate parameter set 2.
- Under Overview, activate function Save set value to EEPROM and enter set value.

Function Save set value to EEPROM has to be activated in order not to lose the set value when switching between parameter sets.

3.4. Fail-safe function

- Fail-safe function is a protective feature in case of unexpected cable break on the MODBUS interface
- If connection with interface is lost, this function allows the motor to run at a pre-set fail-safe operation speed.
- This function is independent from the set value source (Analogue Ain1 or RS485/Bus)

Illustration 22: Fail-safe speed function

Emergency operation function

- Activate Emergency speed by ticking the box
- Enter the Set value emergency operation speed.
- Enter time lag value to determine period of time to elapse before emergency operation speed is to be adopted
- Note exceptions!

Exceptions:

- *Time lag of 0 seconds*
Please note that in this instance the motor adopts fail-safe speed at once – even without cable break. For any such short time lag, we recommend setting the time to 0.1s.
- *Cable break at MODBUS interface and fail-safe function is not activated*
Motor does not stop but continues to run at constant speed. Connection with MODBUS interface has broken down and motor can no longer be controlled. No changes in speed can be effected any more, stopping the motor is no longer possible.
- *Motor to come to complete standstill with cable break (Fail-safe speed = 0 rpm)*
Pre-condition: Motor stop enable must be activated. If this function is not activated, the motor continues to run at minimal PWM-signal.
- *Closing EC-Control, fail-safe speed activated*
If fail-safe speed is activated, the motor adopts this when EC-Control is closed.

3.5. Setting actual value with sensor via ports Ain2 U respectively Ain2 I

If the EC-Motor runs in operation mode Closed-loop sensor control, the actual value is established via sensors. The sensors can indicate pressure, temperature or airflow.

For connecting the sensor, the terminal strip (KL) offers the two analogue ports Ain2 U and Ain2 I (see Illustration 23). Alternatively, terminals Ain1 U and Ain1 I can be chosen. Voltage supply is via terminal 12 with a voltage of +20VDC.

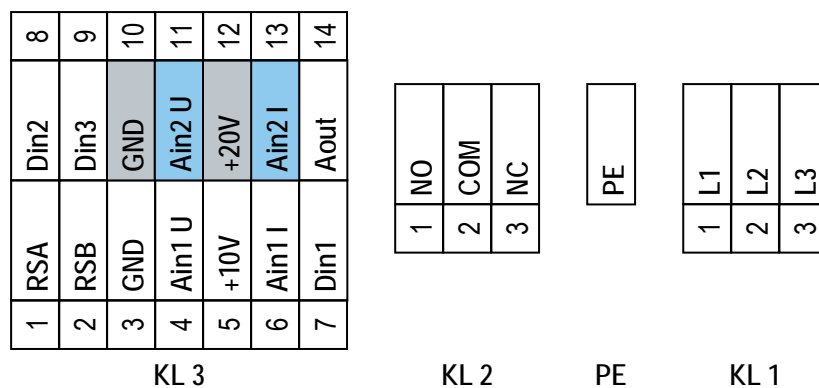

Illustration 23: terminal strip, ports for setting actual value with closed-loop sensor control

Depending on sensor output, two inputs for setting actual value can be used:

- Ain2 U respectively Ain1 U Analogue port 11 respectively 4 (for sensors with 0-10V output)
- Ain2 I respectively Ain1 I Analogue port 13 respectively 6 (for sensors with 4-20mA output)

In principle, there are two different terminal connection methods: 3-wires and 2-wires (see Illustration 24).

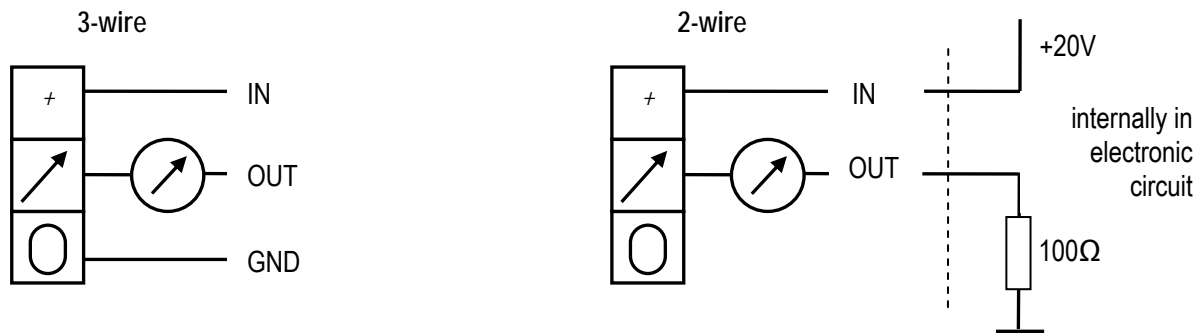

Illustration 24: Terminal connection methods, 3-wire and 2-wire

■ 2-wire sensors

Are directly connected to the voltage source and provide a 4-20mA signal. GND wiring is via internal 100Ω resistor (apparent ohmic resistance) in the fan. On the terminal strip shown in Illustration 23, such a sensor would be connected to Ain2 I and +20V.

■ 3-wire sensors

However, are available with both output signals - current signal (4-20mA) respectively voltage signal (0-10V). Depending on type, inputs Ain2 I (terminal 13) or Ain2 U (terminal 11) have to be used.

On the terminal strip shown in Illustration 23, such a sensor would be connected to Ain2 I respectively Ain2 U, +20V and GND.

3.6. Setting actual value with two sensors

An additional option for setting actual value is to use two sensors at the same time. In the picture shown below (Illustration 25), two temperature sensors with ebm-papst part no. 50005-1-0174 are used.

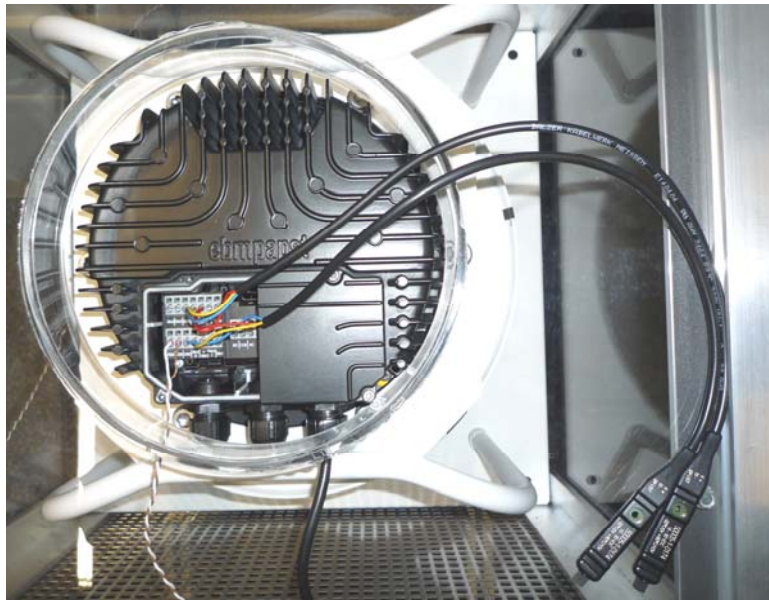

Illustration 25: Connecting two sensors

Two sensors

Example picture

- Two temperature sensors with part no. 50005-1-0174
- Sensor 1:
Ain1 U
+20V
GND
- Sensor 2:
Ain2 U
+20V
GND

The sensor range is from - 20°C to + 80°C. Circuit points Ain1 U and Ain2 U are both used to set actual values. For sensors with a 4-20mA output, terminals Ain1 I and Ain2 I will have to be used accordingly.

For calculating the actual value based on the two measured values, there are the following options:

- Maximum (Ain1:Ain2) the higher of the two sensor values serves as actual value
- Minimum (Ain1:Ain2) the lower of the two sensor values serves as actual value

- Mean (Ain1:Ain2) The mean value of both sensor values serves as actual value

Important note on establishing actual value via two sensors:
 The set value has to be digitally set via EC-Control (Set value source: RS485/Bus), as both analogue ports are already used!

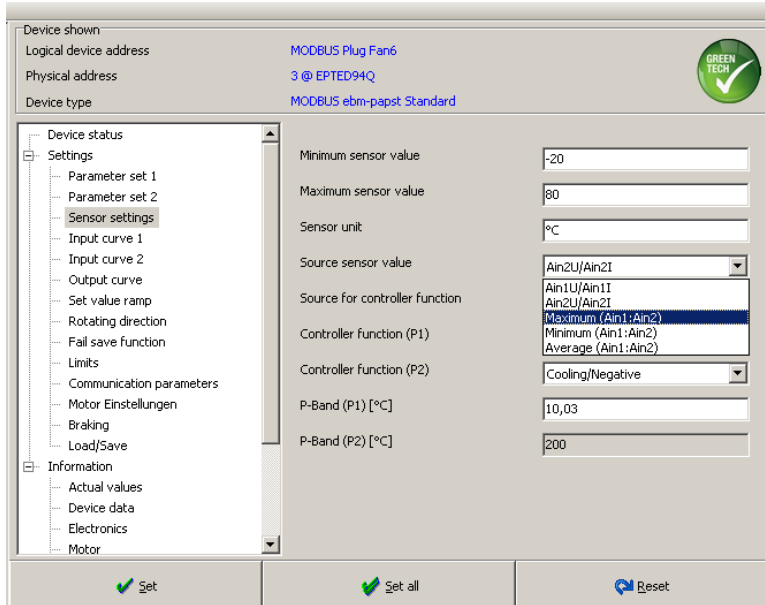

Two sensors Sensor settings

- Sensor range -20°C to 80°C
- Sensor unit: °C
- Under Source sensor value, establishing actual value via two sensors can be selected.
- Always connect sensors to Ain1 U and Ain2 U respectively Ain1 I and Ain2 I with this option.

Illustration 26: Establishing actual value via two sensors

3.7. Set value setting via inputs Ain1 U respectively Ain1 I or via EC-Control

The set value can be set via Analogue Ain1 or via RS485/Bus, independent from the operation mode. The source can be set under Overview (see Illustration 27).

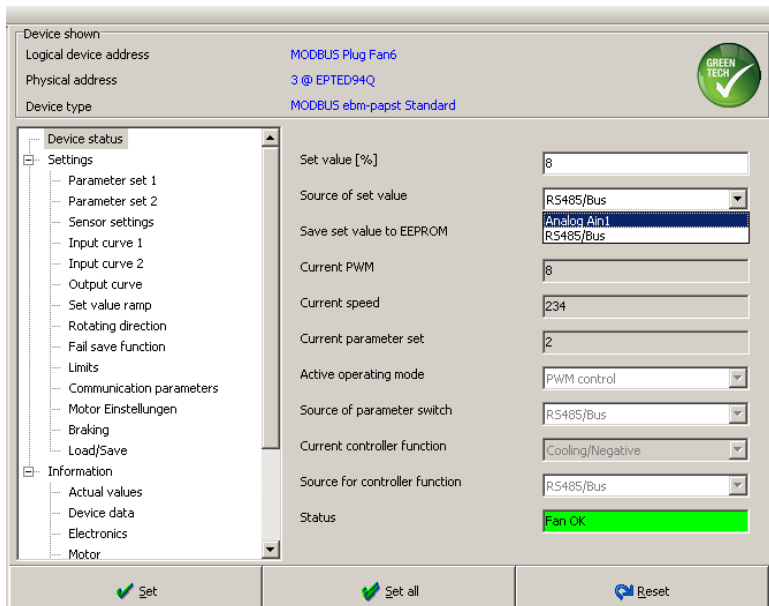

Set value source Analogue Ain1 or RS485/Bus

- Set value source: RS485/Bus
Your set value can be entered digitally in EC-Control
- Set value source: Analogue Ain1
A voltage or a current signal is provided via terminal strip Ain1 U or Ain1 I
- With analogue set value source, the function Save set value to EEPROM has to be deactivated

Illustration 27: Set value source analogue or RS485

Important note for set value source Analogue Ain1:

Make sure to have deactivated Save set value to EEPROM under Device status first!

An external set value source has to be connected to the terminal strip, (e.g. potentiometer). In doing so, terminal 5 can be used as auxiliary voltage source with 10VDC.

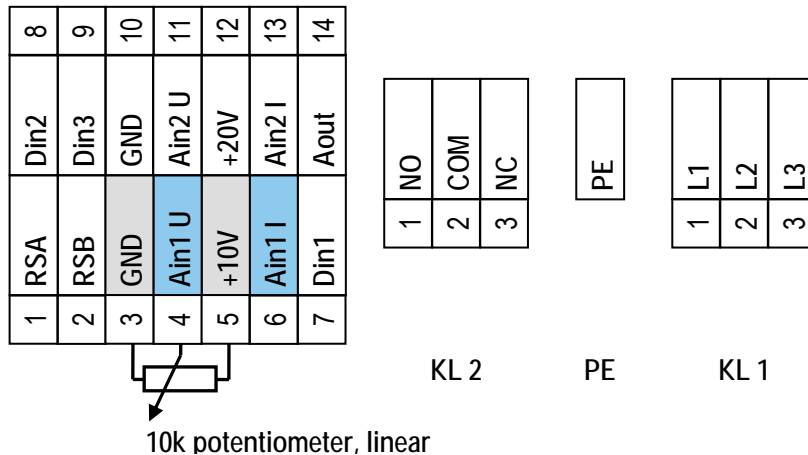

Illustration 28: Terminal strip, ports for setting set values

Terminals 4 and 6 in Illustration 28 are the analogue ports for setting set values. As with setting actual values, there are two different inputs:

- Ain1 U Analogue port 1, terminal 4 for 0-10V setpoint device (e.g. potentiometer)
- Ain1 I Analogue port 1, terminal 6 for 4-20mA setpoint device

3.8. Curves

3.8.1. Input curve

The input curve is only relevant with analogue definition of set value (Source of set value: Analogue Ain1). If set value is given via EC-Control (Source of set value: RS485/Bus), this point is without function.

With set value source Analogue Ain1, the function Save set value to EEPROM has to be deactivated.

- With set value source Analogue Ain1 via analogue ports Ain1 U respectively Ain1 I, it is possible to define the input curve.
- Under Settings, you find the sub-item Input curve 1 respectively Input curve 2
- For both input curves taken from Illustration 30, standstill of the motor with a 0V signal would only be possible if the function Motor stop enable were to be activated.

Device shown
 Logical device address: MODBUS Plug Fan6
 Physical address: 3 @ EPTED94Q
 Device type: MODBUS ebm-papst Standard

Device status
 Settings
 Parameter set 1
 Parameter set 2
 Sensor settings
 Input curve 1
 Input curve 2
 Output curve
 Set value ramp
 Rotating direction
 Fail save function
 Limits
 Communication parameters
 Motor Einstellungen
 Braking
 Load/Save
 Information
 Actual values
 Device data
 Electronics
 Motor

Input curve X1 (P1) [V]: 0
 Input curve Y1 (P1) [rpm]: 100
 Input curve X2 (P1) [V]: 10
 Input curve Y2 (P1) [rpm]: 700

Buttons: Set, Set all, Reset

Input curve Parameter set 1

- Example Parameter set 1:
Operation mode: closed-loop speed control
- Example left: Linear progression from 100 to 700rpm
- Input curve can be set for both parameter sets independently from each other.
- Deactivate Save set value to EEPROM as set value source is Analogue Ain1.
- Curve, see Illustration 30

Device shown
 Logical device address: MODBUS Plug Fan6
 Physical address: 3 @ EPTED94Q
 Device type: MODBUS ebm-papst Standard

Device status
 Settings
 Parameter set 1
 Parameter set 2
 Sensor settings
 Input curve 1
 Input curve 2
 Output curve
 Set value ramp
 Rotating direction
 Fail save function
 Limits
 Communication parameters
 Motor Einstellungen
 Braking
 Load/Save
 Information
 Actual values
 Device data
 Electronics
 Motor

Input curve X1 (P2) [V]: 5,00
 Input curve Y1 (P2) [%]: 20
 Input curve X2 (P2) [V]: 8
 Input curve Y2 (P2) [%]: 80

Buttons: Set, Set all, Reset

Input curve Parameter set 2

- Example Parameter set 2:
Operation mode: PWM control
- Example left: Power factor control > 20% is only possible as of 5V input voltage
- Input curve can be set for both parameter sets independently from each other.
- Deactivate Save set value to EEPROM as set value source is Analogue Ain1.
- Curve, see Illustration 30

Illustration 29: Input curve

Input curve Parameter set 1

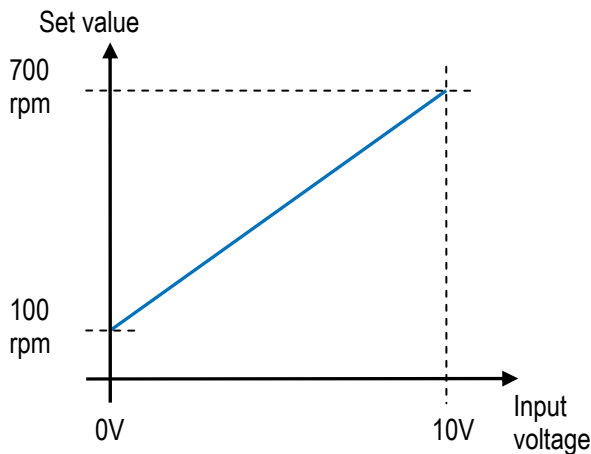

Input curve Parameter set 2

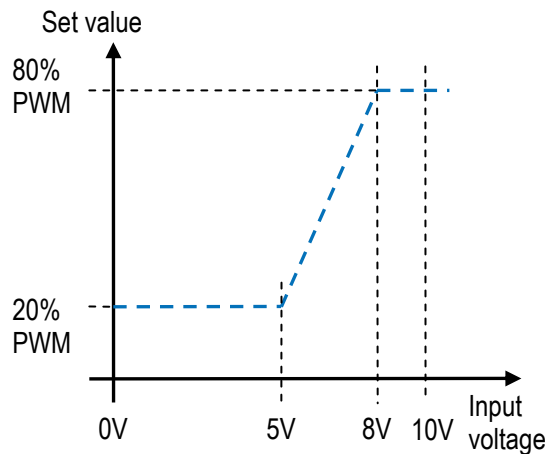

Illustration 30: Examples for input curves of P1 and P2

3.8.2. Inverse curves

The input curve is only relevant with analogue definition of set values (Source of set value: Analogue Ain1). If set value is given via EC-Control (Source of set value: RS485/Bus), this point is without function.

With set value source Analogue Ain1, the function Save set value to EEPROM has to be deactivated.

With analogue definition of set value, the input curve also offers the chance to generate an inverse curve. This means that the phase control factor increases with a decreasing input signal.

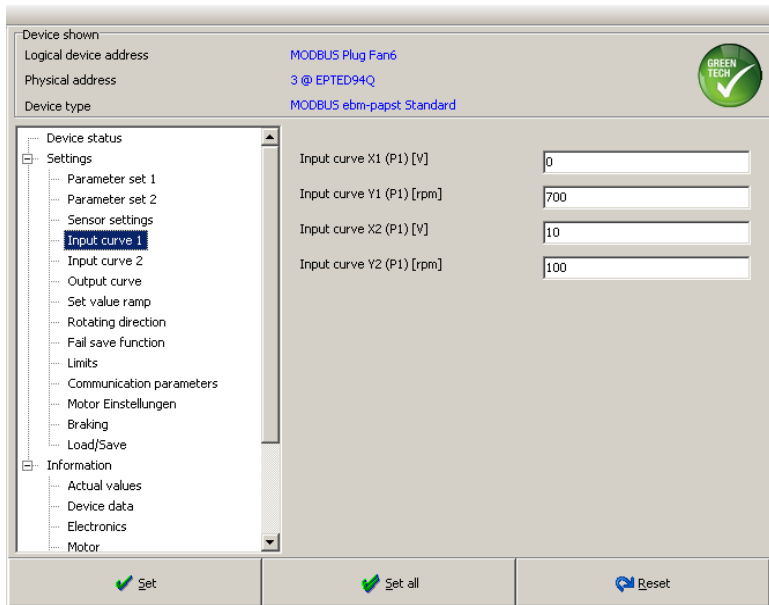

Inverse curve

- Curve from Illustration 30 was inverted
- Example input voltage:
0V → 700 rpm
10V → 100 rpm
- Increasing the signal reduces the phase control factor

Illustration 31: Inverse curve

The inverse curve becomes clear when comparing above Illustration 30 with Illustration 32 below.

Inverse input curve Parameter set 1

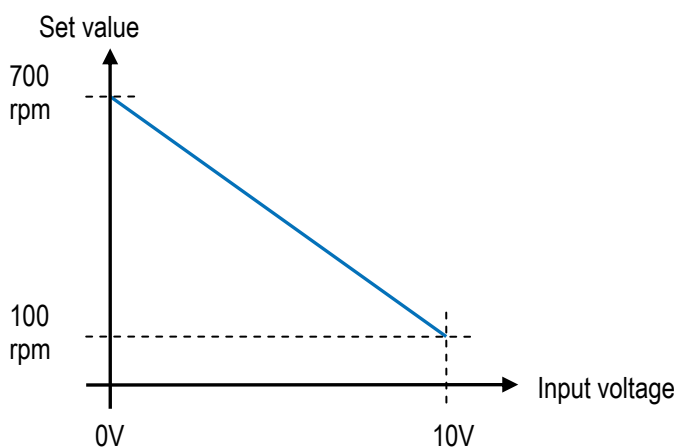
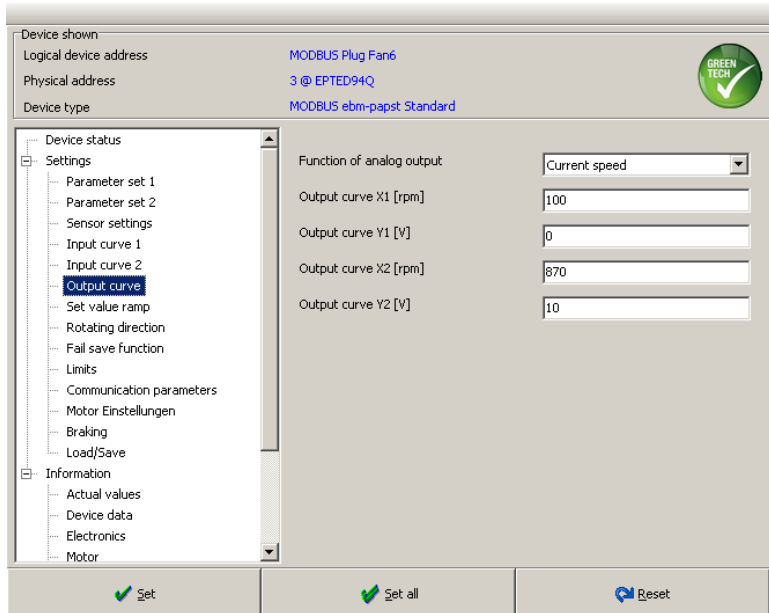

Illustration 32: Example of inverse curve

In practice, we know applications where an inverse curve guarantees that the fan operates with maximum phase factor control from analogue set value (→ input signal 0V) even with cable break.

3.8.3. Output curve

In order to connect further slaves to a master fan, the terminal MODBUS strip has an output Aout. Depending on speed respectively PWM signal, this output yields a voltage signal that is constantly given. The set value source is irrelevant for this.



Output curve

- Coordinates of output curve can be entered here
- Output curve, see Illustration 34 left
- The output curve can be geared to Actual-PWM or actual speed, depending on *Function of analogue output*

Illustration 33: Output curve

The output curve thus generated can be adapted individually to your needs. The menu item *Settings* gives you the sub-item *Output curve* (see Illustration 33). The function of the analogue output indicates whether the x-axis represents speed or the PWM-signal. The output curve would look like this:

Function *Actual speed*

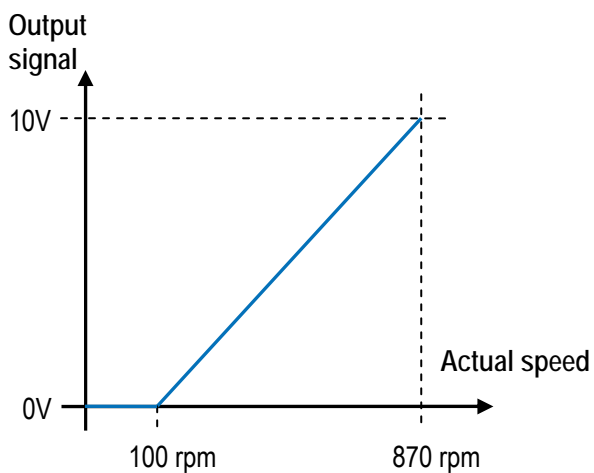

If the motor runs at a speed of 870 rpm, there is a voltage of 10V at the output Aout. With speeds ≤ 100 rpm, a 0V-signal is generated. Maximum speed is limited as per setting dialogue *Limits* (here 870 rpm).

Function *PWM-Signal*

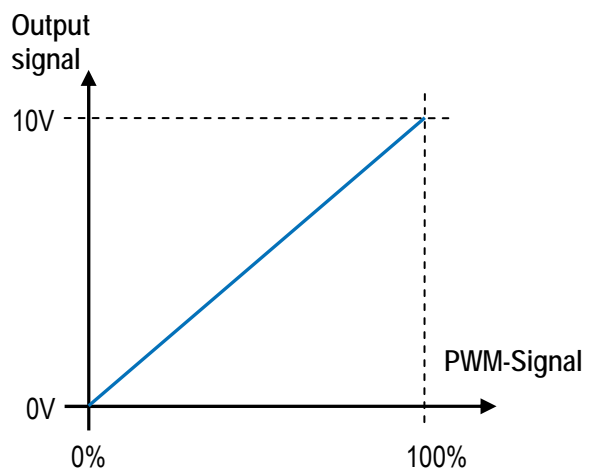

If the motor runs at a PWM-signal of 100%, there is a voltage of 10V at the output Aout. The curve has a linear progression. With 0% PWM-signal, the output issues a 0V-signal.

Illustration 34: Output curve

4. Use of EC-Control in customer applications

The following points can be taken as exemplary advice on setting parameters and give connection diagrams of typical customer applications. They are to be taken as recommendations and do not constitute binding specifications for the relevant application. Settings concerning the **master** are indicated by a **green** background. Settings concerning the **slaves** are marked in **orange**. Settings concerning all members are in **green** and **orange**.

4.1. Refrigeration plants

4.1.1. Master-Slave configuration (star-shaped)

In a refrigeration plant, one fan normally serves as master and the others are slaves.

In order to set such an operation to closed-loop pressure control, ebm-papst recommends defining the following system settings for the master respectively the slaves in EC-Control. The objective is to keep condensing pressure constant.

Illustration 35: Parameter set settings for master of refrigeration plant

Illustration 36: Sensor settings for temperature sensor of master

Step 1: Setting Parameter Set

Master fan

- Setting operation mode:
Closed-loop sensor control
- Active direction: *Cooling/Negative*
- P-Factor: 2000%
I-Factor: 0%
pure P-control
- Source for parameter set selection:
normally *RS485/Bus*,
Terminal *Din2* respectively *Din3*
can also be set.

Step 2: Defining sensor settings

Master fan

- Select sensor range (max, min),
here: 0...30 bar
- Consult manufacturer information
- Sensor unit: bar
- Connect sensor and select
appropriate actual value source,
provided are *Ain2U/Ain2I*
- Source of active dir.: *RS485/Bus*
- Active direction *Cooling/Negative*
- Control range: 1.5 bar

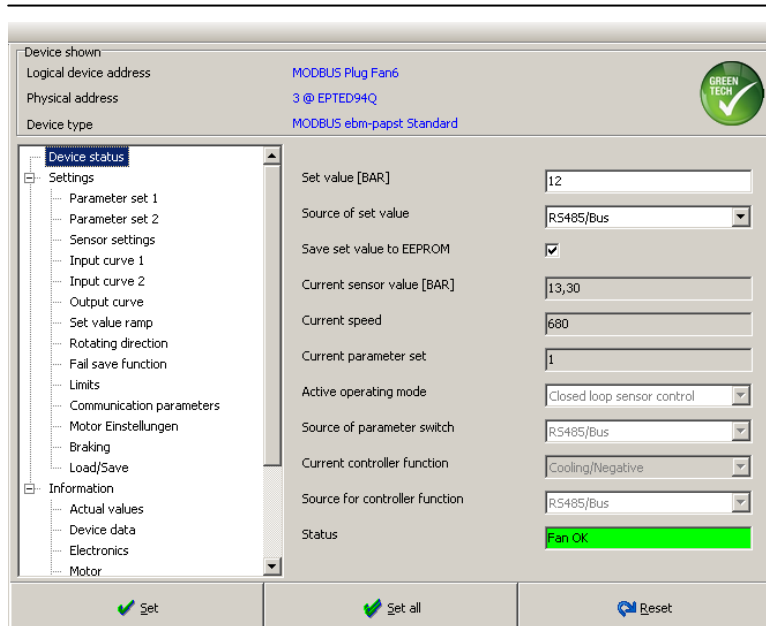

Illustration 37: Entering set values of master

Step 3: Enter set value settings for master

Master fan

- Activate Save set value to EEPROM
- Set value source: RS485/Bus
- Enter set value
- Set values can only be saved in the active parameter set

The slaves get their set value in the form of a 0-10V signal from the Aout port of the master via their terminals Ain1 U and GND. The output curve of the master is therefore set as shown in Illustration 38. The progression of the curve is linear and Actual PWM is selected as the function of the analogue output.

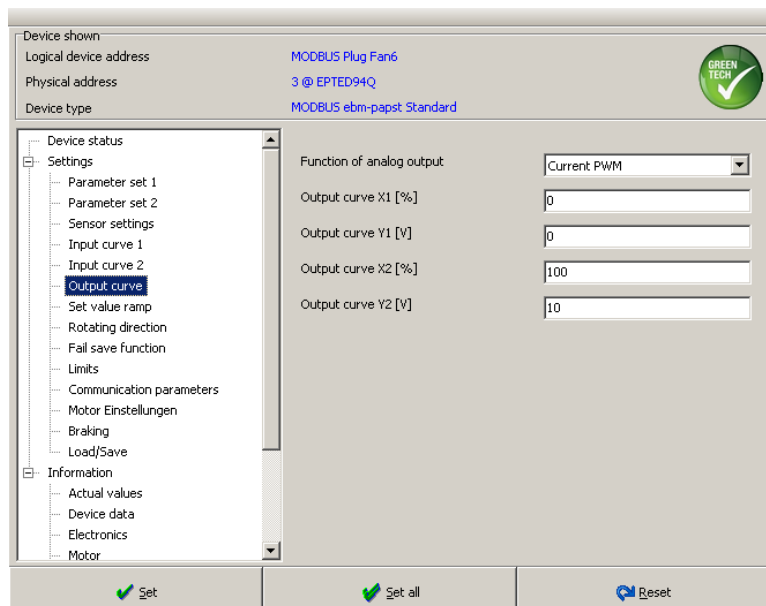

Illustration 38: Output curve for master with refrigeration plants

Step 4: Output curve of the master

Master fan

- Function of the analogue output: Actual PWM [%]
- Output curve linear
0% correspond to 0V
100% correspond to 10V

Slave settings (see below):

As the slaves do not need a sensor or two parameter sets, their system settings are comparatively easy to accomplish (see Illustration 39).

Important note concerning slave settings:
Steps 5, 6 and 7 have to be done for ALL slaves.

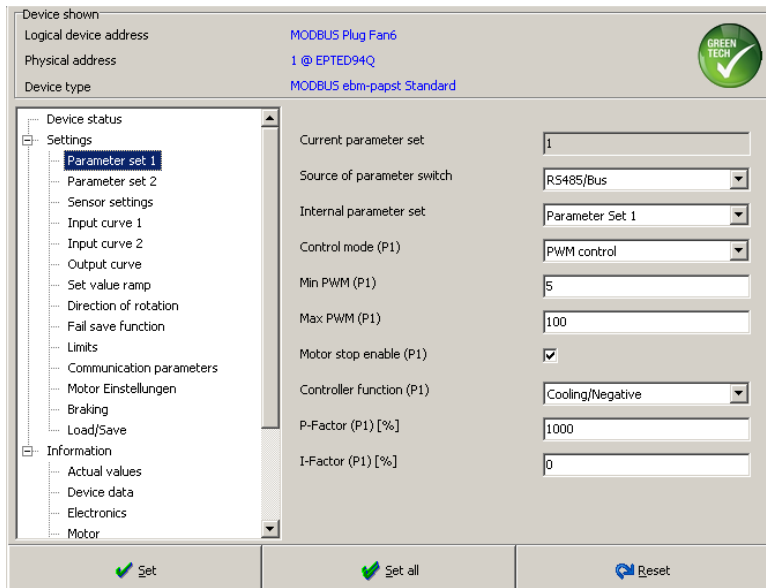

Step 5:
Operation mode of slaves:
PWM control

- Slave fans**
- Operation mode: PWM Control
 - For slaves, only one parameter set has to be configured, here P1
 - Active direction and P- respectively I-Factor in operation mode PWM control not relevant
 - Activate Motor stop enable

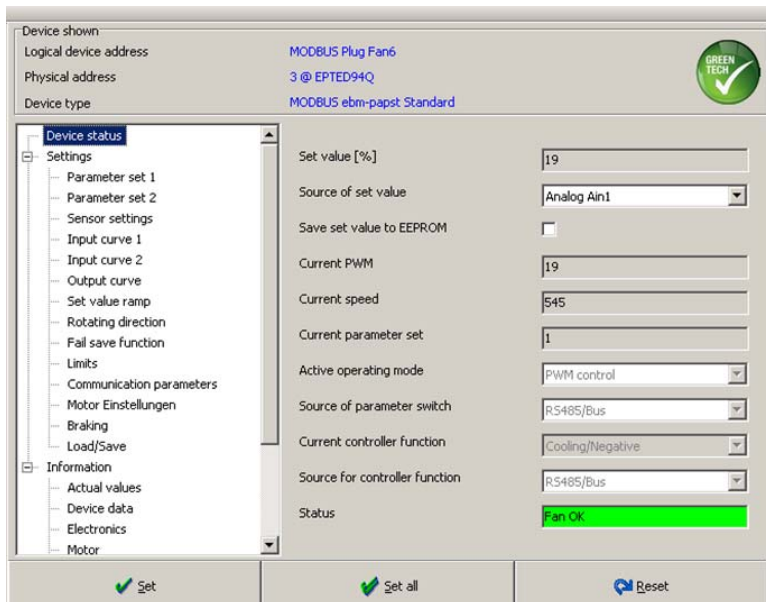

Step 6:
Overview, analogue set value
source

- Slave fans**
- Set value source: Analogue Ain1
 - Deactivate Save set value to EEPROM
 - Slaves get 0-10V signal from master output

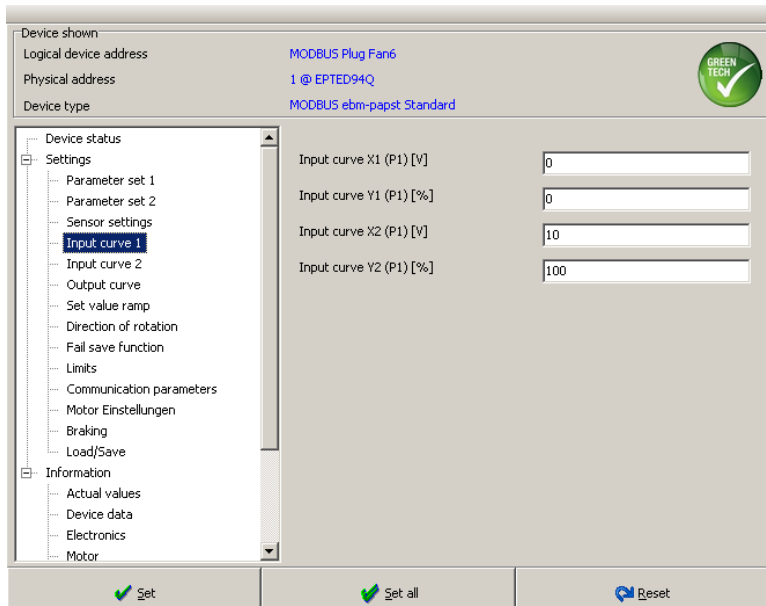

Step 7:
Input curve

- Slave fans**
- Linear input curve for slaves

Illustration 39: Settings for slave fans

Illustration 40 on the next page shows the connection diagram of master and slaves in a refrigeration plant.

- Fans are arranged in star shape
- Set value is given by the master via output Aout as 0-10V signal on a patch panel. To this distributor, the set value source Ain1 U of the respective slaves is connected.
- Operation mode master: Closed-loop sensor control
Operation mode slaves: PWM control and set value source Analogue Ain1

The advantage of such a star-shaped configuration over the serial one (connection in series)

- With defects, the relevant device can be replaced easily and quickly without having to disconnect the entire system. The only problem is with long distances, as a considerably larger amount of lines has to be used.

As an alternative to the pressure sensor used in the example, there are also 2-wire sensors that do not require a GND connection. Their output signal can be a current signal with 4-20mA. In this case, the sensor would have to be connected to the actual value input Ain2 I and terminal +20V (see also chapter 3.5)

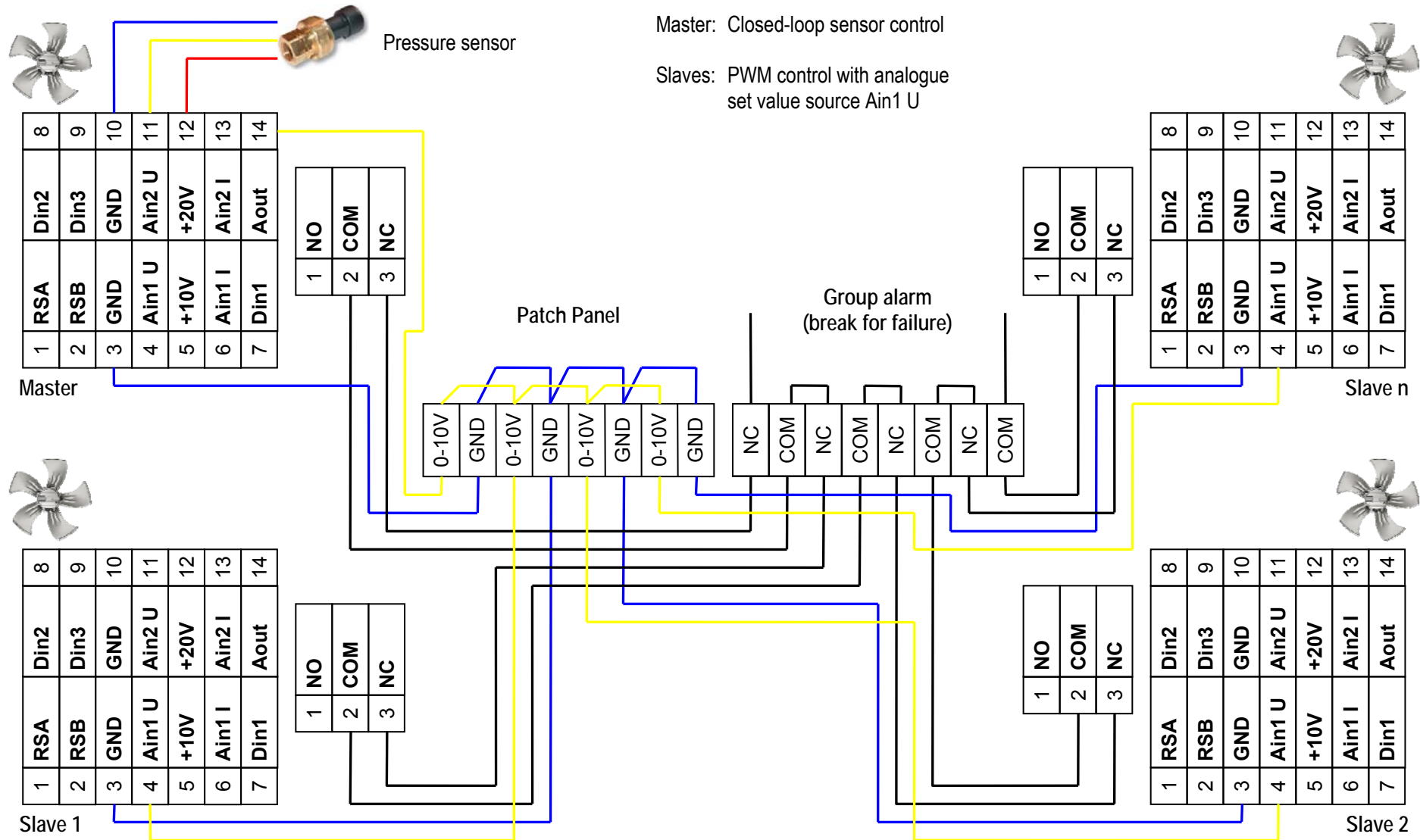

Illustration 40: Connection diagram, star-shaped Master-Slave configuration for refrigeration plants

4.1.2. Master-Slave configuration with cascading mode

Another possible Master-Slave configuration is cascading mode. The master gives off the set value in the form of a 0-10V signal via analogue output Aout to the first slave. Other than with the star-shaped configuration shown in Illustration 40, the slaves here are not connected in parallel, but in series, and the output curve of all members gets aligned.

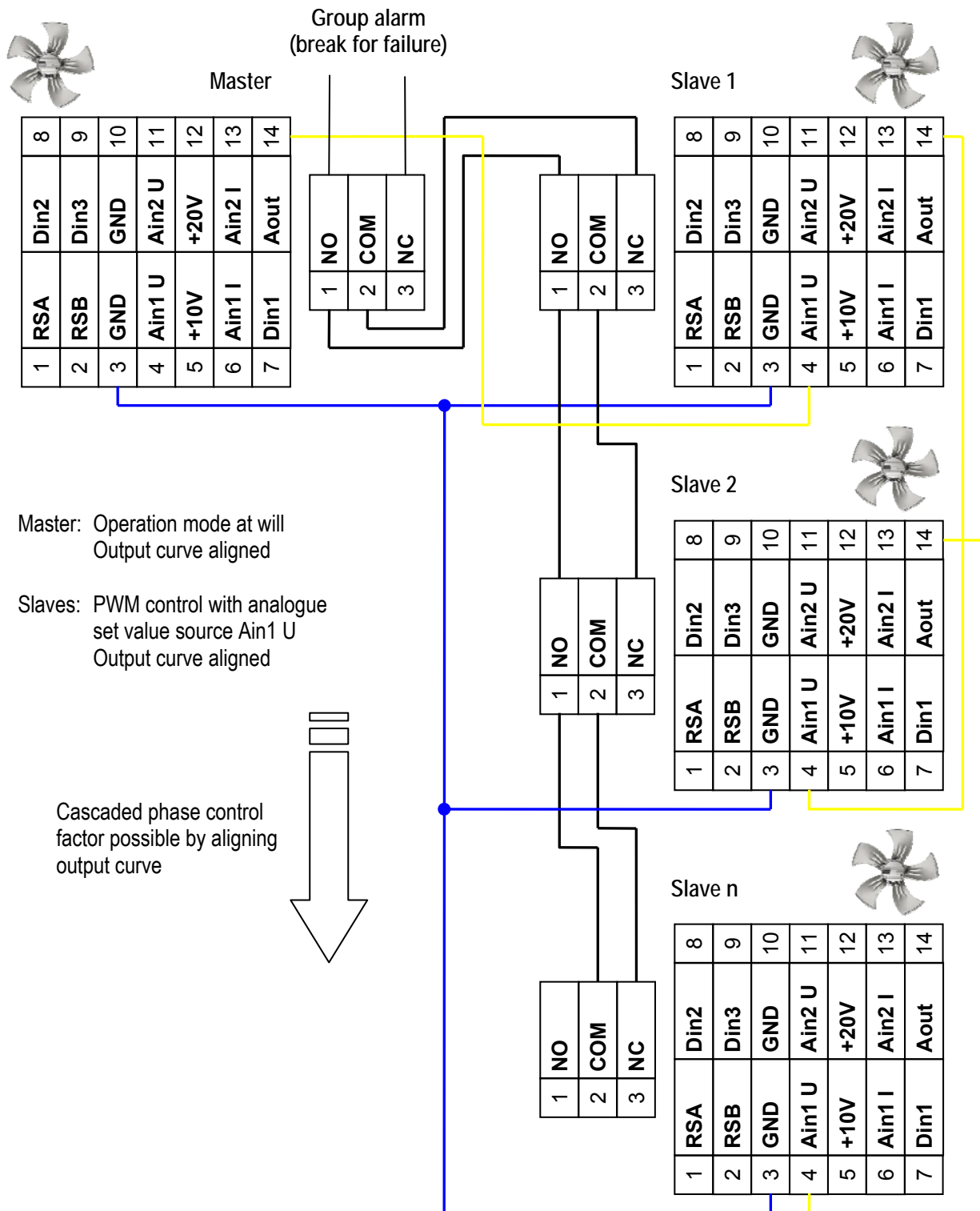

Illustration 41: Connection diagram, cascading mode, Master-Slave configuration for refrigeration plant

Requirement for cascading mode:

- Operation mode of master at will
- Operation mode of slaves: *PWM_control*
- Set value source slaves: *Analogue Ain1* and *Save set value to EEPROM* deactivated
- Input curves of all members unchanged (0V / 0% and 10V/100%)
- Aligned output curve for master and all slaves, example Illustration 42

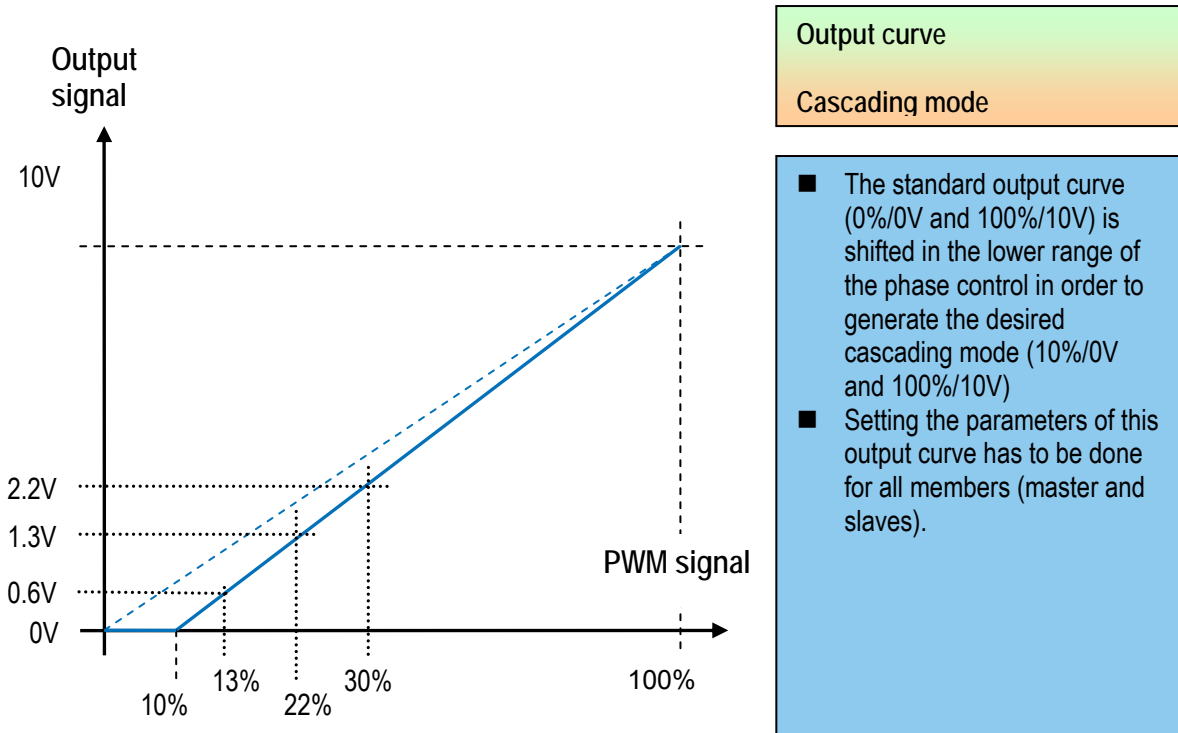

Illustration 42: Output curve for cascading mode

Illustration 42 shows a curve as an example where, whenever the master runs at low speed, the slaves assume an even lower speed in turns. This should result in the last slaves in the chain switching off.

Rule applying to the output curve above:

The higher the speed of the master, the lower the difference to the rest of the members. With full phase control of the master, the slaves will also run at 100%.

First example: Master = 30%. The phase control factor of the master is to be 30%.

- As per output curve in Illustration 42, it gives off a signal of about 2.2V to slave 1
→ therefore phase control factor Slave 1 = 22%
- Slave 1 has the same output curve as the master and thus passes a signal of about 1.3V to slave 2
→ therefore phase control factor Slave 2 = 13%
- Slave 2 has the same output curve as Master, thus passing on a signal of < Min. PWM to slave 3
→ therefore phase control factor Slave 3 = 0%, and thus standstill

Second example: Master = 100% phase control factor

- As per output curve in Illustration 42, it gives off a signal of about 10V to slave 1
→ therefore phase control factor Slave 1 = 100%
- Slave 1 has the same output curve as Master and thus passes on a signal of about 10V to Slave 2
→ therefore phase control factor Slave 2 = 100%
- Slave 2 has the same output curve as Master and thus passes on a signal of about 10V to Slave 3
→ therefore phase control factor Slave 3 = 100%

Cascading mode should only be realised with maximally 3-4 slaves.

Illustration 43 shows the settings you need to define in EC-Control for input and output curve with cascading mode as per Illustration 42. The important thing is not to change the input curve and to have it set in the standard settings. In addition to Illustration 43, the operation mode *PWM Control* together with set value source *Analogue Ain1* has to be selected for the slaves. The function *Save set values to EEPROM* has to be deactivated for the slaves.

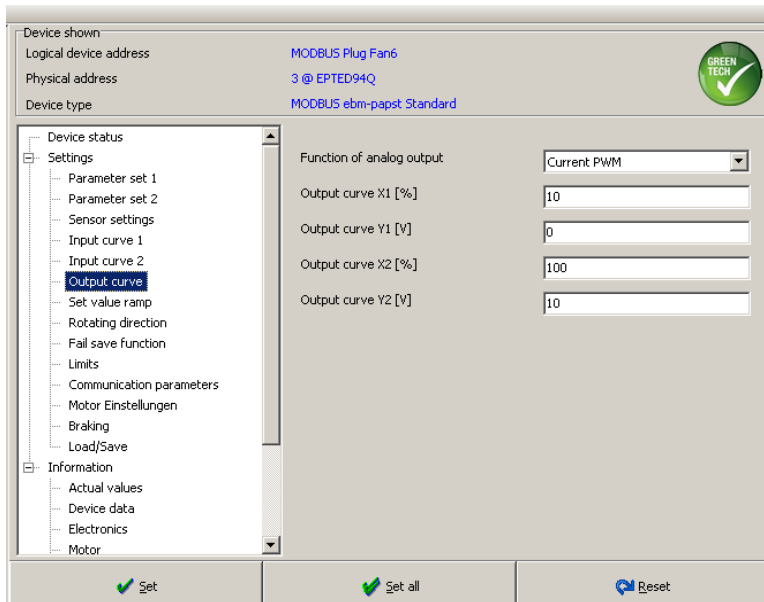

Output curve

- Output curve of the master and of all slaves has to be aligned
- Coordinate X1 to be shifted by 10% compared to standard curve

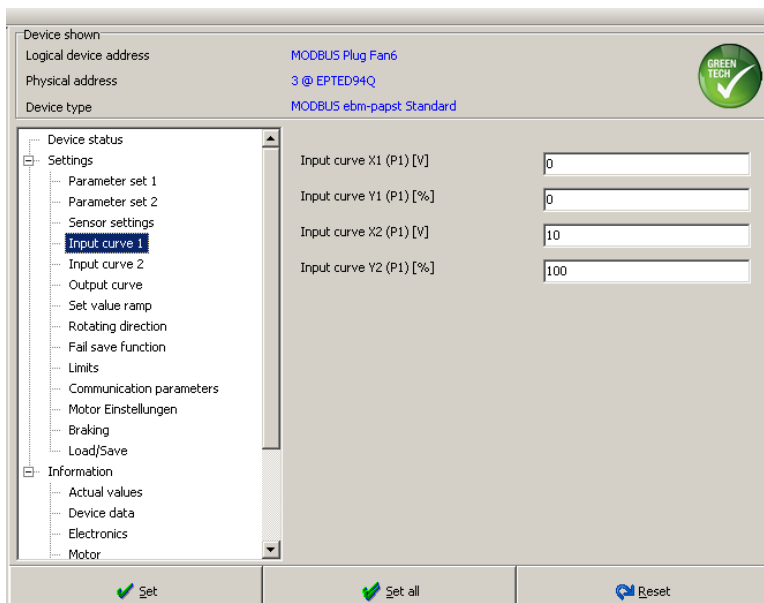

Input curve

Slave fans

- Only relevant for slaves
- Linear input curve
- Input curve of all slaves has to be set to standard (0V/0% and 10V/100%)

Illustration 43: Output and input curve for cascading mode

4.1.3. Reverse mode to clean and defrost exchanger

Reverse mode allows you to change the direction of rotation of a fan. Devices equipped with MODBUS interface and protocol version greater or equal to V3.02, it is possible for the user to change the direction of rotation himself via digital input Din3.

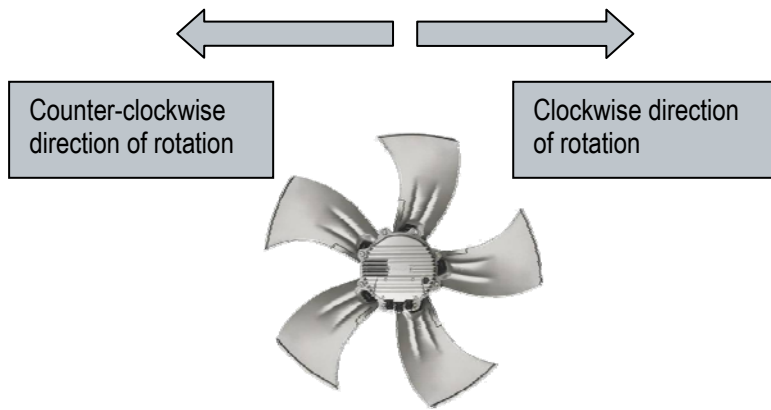

Preferential direction of rotation is factory setting; reverse mode means direction of rotation is opposite the preferential direction of rotation.

Any statements as to whether direction of rotation is clockwise or counter-clockwise are therefore impossible to make.

Illustration 44: Direction of rotation of an axial fan

Example: Switch between two parameter sets including reverse mode

- P1 operation mode PWM Control, direction of rotation defined by factory settings
- P2 operation mode Closed-loop speed control, direction of rotation opposite the preferential direction of rotation

To realise this operation, the following setting steps have to be gone through in their correct sequence:

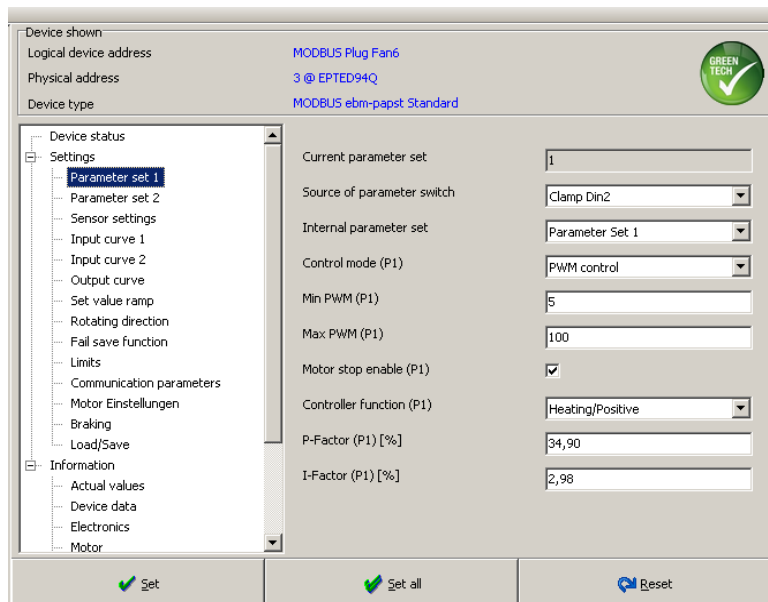

Step 1: Defining parameter set 1

- Source for parameter set: Clamp Din2, to change direction of rotation and switch parameter set at almost the same time (by bridging Din2 and GND)
- Operation mode: PWM control
- P- respectively I-Factor and active direction irrelevant for PWM control

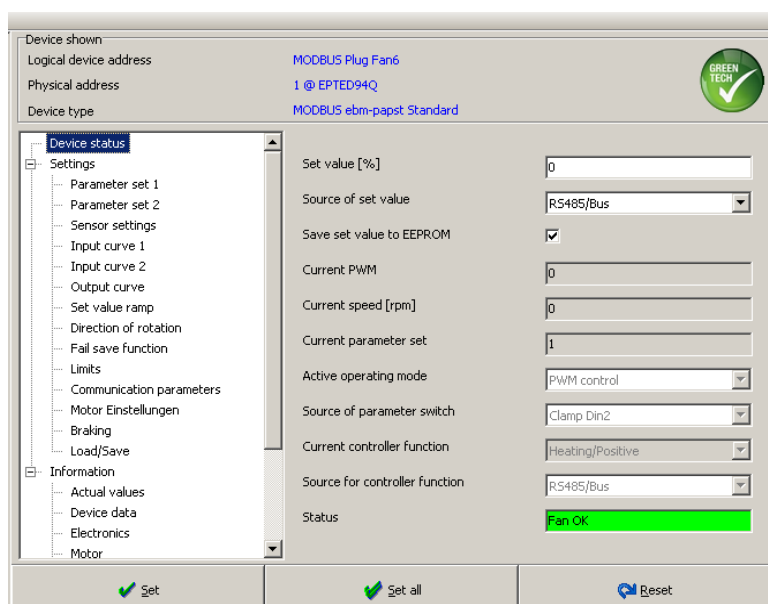

Step 2: Select set value source RS485/Bus

- Parameter set 1 has to be activated
- Set value source: RS485/Bus
- Activate Save set value to EEPROM
- Enter Set value [%]

Illustration 45: Parameter set 1

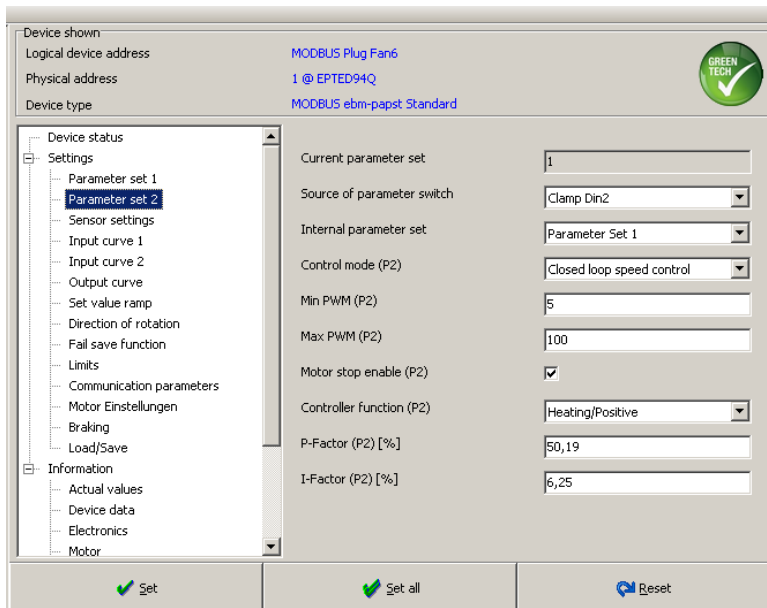

Step 3: Define parameter set 2

- Source of parameter switch: has already been assigned to Clamp Din2
- Operation mode: Closed-loop speed control
- P-Factor: 50%
- I-Factor: 6.25%
- Controller function irrelevant for PWM control

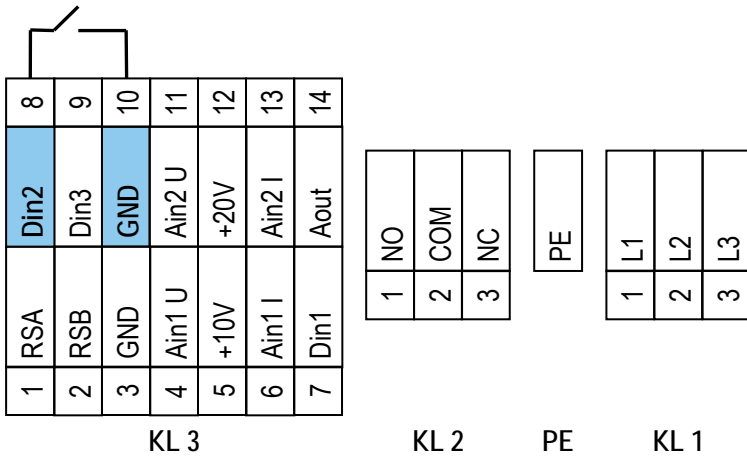

Step 4: Activate parameter set 2

- Activate parameter set 2 by bridging GND to Din2
- Step 5 can only be executed if P2 is activated in step 4.

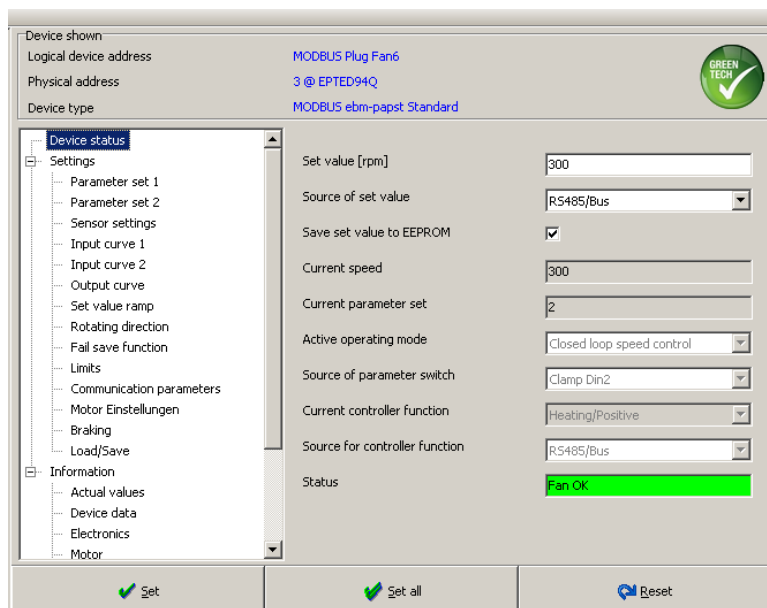

Step 5: Enter and save set value

- Parameter set 2 has to be activated first (see step 4)
- Set value source: RS485/Bus
- Activate Save set value to EEPROM
- Enter Set value [rpm]

Illustration 46: Parameter set 2

Parameter set 1 and preferential direction of rotation:	Din2 open or applied voltage 5...50V
Parameter set 2 and reverse mode:	Bridge to GND or applied voltage < 1V

In order to change direction of rotation and parameter set at the same time, Source of rotating direction and Source of parameter switch have to be identical (either Clamp Din2 or Clamp Din3).

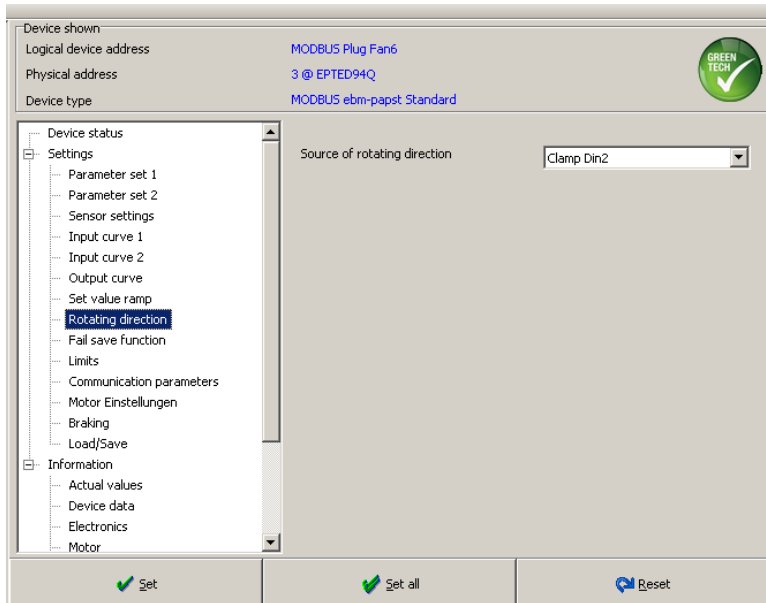

Step 6:
Source of rotating direction

- Direction of rotation source Clamp Din2
- Source of rotating direction has to be the same terminal as source for parameter set

Illustration 47: Reverse mode, direction of rotation source

Switching between both parameter sets and changing direction of rotation at the same time is done by bridging Din2 to GND.

4.2. Notes on setting parameters for closed-loop airflow control in air-con units

The differential pressure method compares the static pressure before the inlet nozzle with the static pressure in the inlet nozzle of an EC centrifugal fan. Flow rate [m³/h] can be calculated on the basis of differential pressure (differential pressure of the static pressures in [Pa]) as per following equation:

$$\dot{V} = k \times \sqrt{\Delta p_w} \quad \text{respectively} \quad \Delta p_w = \frac{\dot{V}^2}{k^2}$$

In the ebm-papst product catalogue “Plug Fans with EC-Motor”, the following table for the k-values depending on the size of the fan is given. The table refers to backward-curved centrifugal fans.

Inlet nozzles with measuring device to determine air flow for backward curved centrifugal fans

Part no.	Part no.	Size	k-value	For dimensions, see
25075-2-4013 ⁽¹⁾ / 25080-2-4013 ⁽²⁾		250	70	page 7
28075-2-4013 ⁽¹⁾ / 28080-2-4013 ⁽²⁾		280	93	page 9
31575-2-4013 ⁽¹⁾ / 31580-2-4013 ⁽²⁾		310	116	page 11
35675-2-4013 ⁽¹⁾ / 35680-2-4013 ⁽²⁾		355	148	page 13 / 15
40075-2-4013 ⁽¹⁾ / 40080-2-4013 ⁽²⁾		400	188	page 17
45075-2-4013 ⁽¹⁾ / 45080-2-4013 ⁽²⁾		450	240	page 19
64025-2-4013 ⁽¹⁾ / 64002-2-4013 ⁽²⁾		500	281	page 21
64030-2-4013 ⁽¹⁾ / 64001-2-4013 ⁽²⁾		560	348	page 23

subject to alterations ⁽¹⁾ with one pressure tap ⁽²⁾ with piezometer ring (4 pressure taps connected by tubing)

With constant nozzle pressure, constant airflow can be controlled accordingly. One respectively four pressure taps to measure Δp_w are situated along the circumference of the inlet nozzle.

Example to demonstrate this:

- Hall with a floor space of 600m², 3m in height
- Air volume of the room is therefore 1800m³.
- This volume is to be completely exchanged via fans every 30 minutes
→ Air flow is thus 3600 m³/h
- Product used: R3G450-AY86-01, k-value = 240
→ Differential pressure therefore $(3600/240)^2 = 225$ Pa

Differential pressure in the nozzle has to be kept at a constant 225 Pa. The fan provides constant volume irrespective of pressure conditions in the plant. Fan speed is automatically adjusted along its vertical curve.

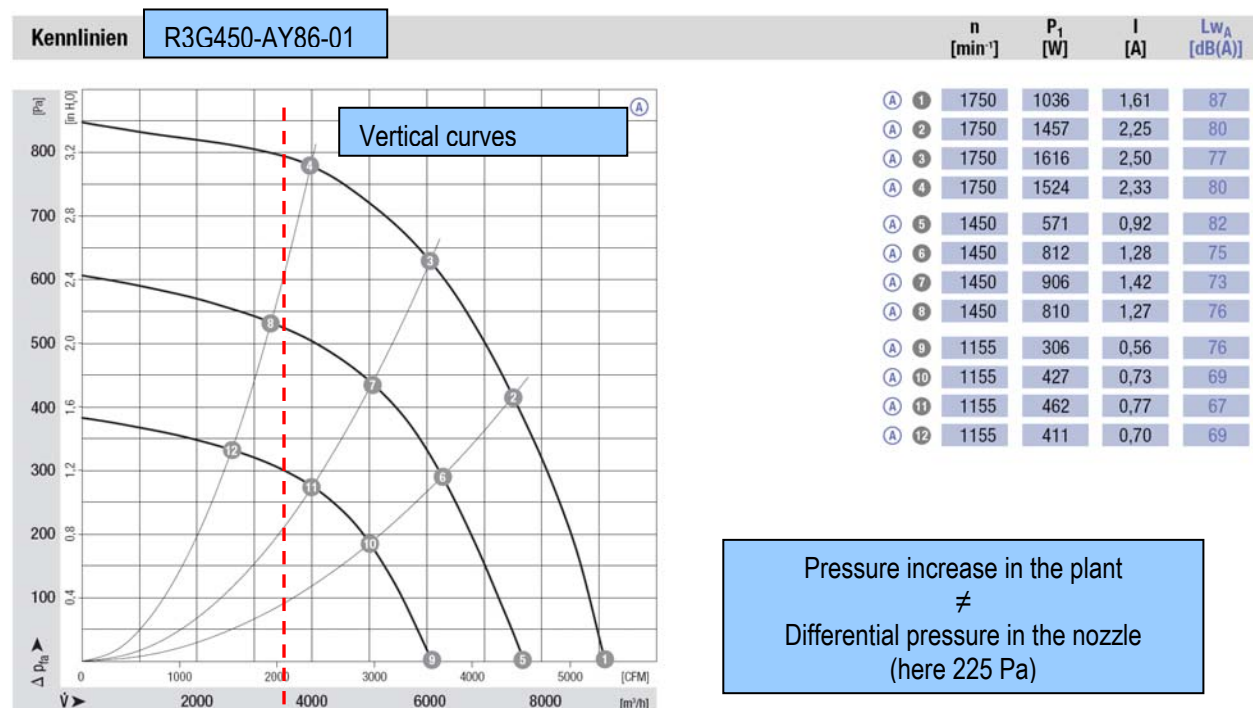

Illustration 48: Characteristic curves, diagram for R3G450-AY86-01

Based on the expected differential pressure in the nozzle, here is some advice on setting parameters for EC-Control.

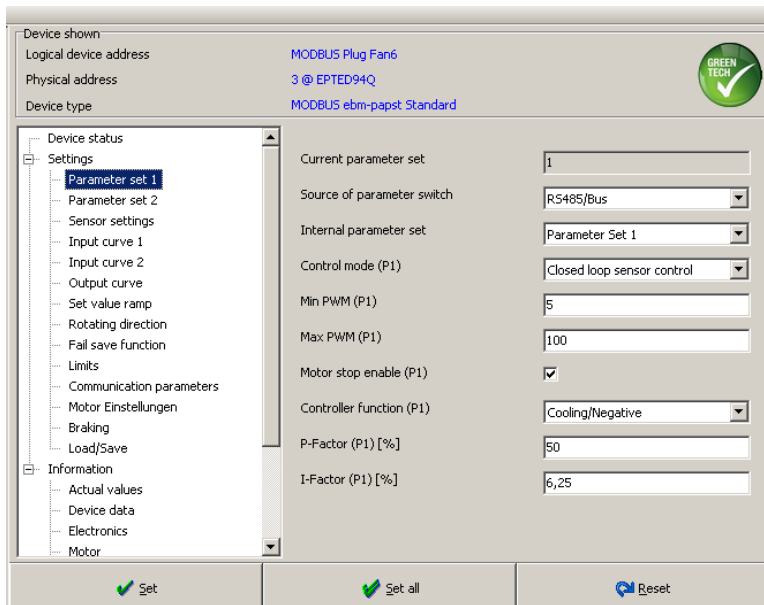

Illustration 49: Parameter set 1

Step 1:

Define parameter set 1

- Operation mode: *Closed-loop sensor control*
- Source for parameter set: *RS485/Bus*
- *P-Factor:* 50%
- *I-Factor:* 6.25%
- Activate parameter set 1

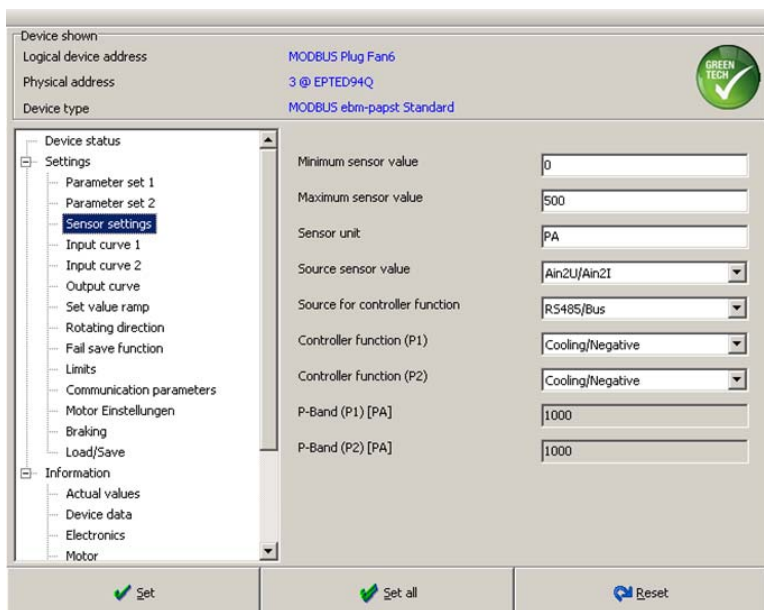

Illustration 50: Sensor settings for pressure sensor

Step 2:

Sensor settings, 0...500 Pa

- With 0...500 Pa sensor
Min. sensor value: 0 Pa
Max. sensor value: 500 Pa
- *Sensor unit:* Pa
- Select *Source sensor Value* accordingly
- Alternative sensor type: 0...1000 Pa

4.2.1. Digital definition of set values with closed-loop airflow control, e.g. Day/Night mode switch

As per equation given in chapter 4.2, changing the differential pressure in the nozzle can also change the airflow. For the above example with Plug Fan R3G450-AY86-01, a k-value of 240, and a 0...500 Pa pressure sensor, we get the curve given in Illustration 51. The ratio between differential pressure and sensor voltage is thus defined as:

- A differential pressure of 500 Pa corresponds to a sensor voltage of 10V.

- A differential pressure of 225 Pa corresponds to a sensor voltage of 4.5V (see Illustration 51 broken line)
- A differential pressure of 0 Pa corresponds to a sensor voltage of 0 V

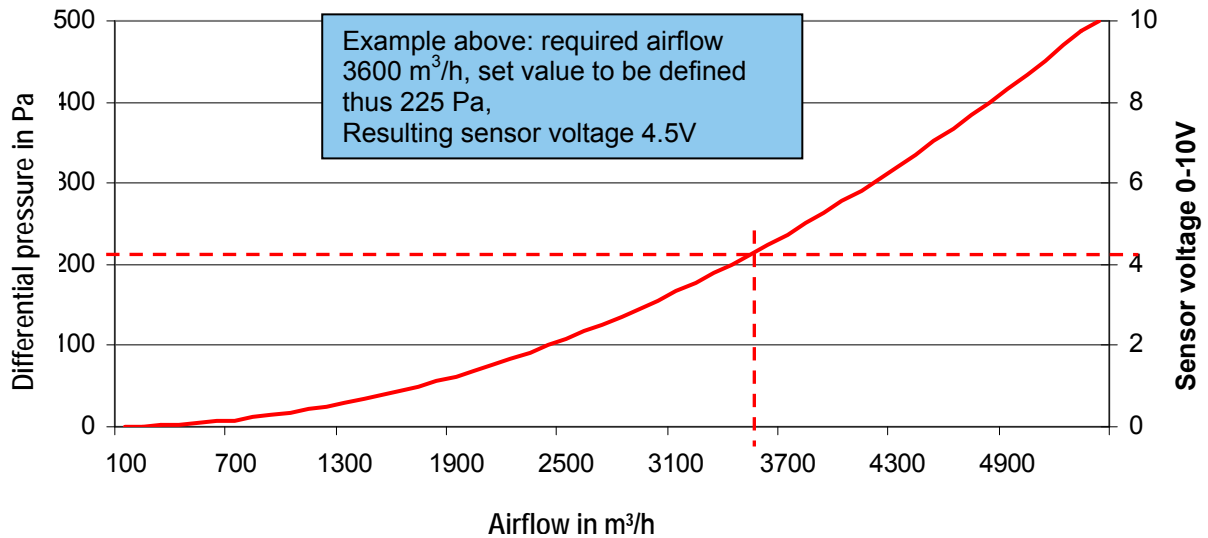

Illustration 51: Pressure curve, airflow curve

Once all settings from chapter 4.2 have been defined, you can finally enter the set value for the differential pressure (225 Pa) under Device status (see Illustration 52). This digital definition of the set value is done via EC-Control. Maintaining a constant pressure of 225 Pa in the nozzle guarantees constant airflow – here 3600m³/h.

Step 3a:
Defining set value via RS485/Bus

- Set value here: 225 Pa Day mode
- Set value source: RS485/Bus
- Activate Save set value to EEPROM
- Enter required differential pressure under Set value to control to constant airflow
- Set value ≈ Actual value

Illustration 52: Digital set value definition for parameter set 1, differential pressure 225 Pa, enter set value for Day mode

Optionally, a second parameter set can be defined, for instance for a so-called Day/Night switch:

Once the sensor settings have been defined, the following steps have to be taken to save set values for P1 and P2 (Click on Set required after each step):

- Under Parameter set 1, activate parameter set 1 and define settings (see Illustration 49)
- Under Device status, activate function Save set value to EEPROM (see Illustration 52)
- Under Device status, enter set value (see Illustration 52)
- Under Parameter set 2, activate parameter set 2 and define settings (see Illustration 53)
- Under Device status, activate function Save set value to EEPROM (see Illustration 54)

■ Under Device status, enter set value (see Illustration 54)

The screenshot shows the 'Parameter set 2' configuration page. On the left, a tree view shows 'Settings' expanded to 'Parameter set 2'. The main area contains the following fields:

- Current parameter set: 2
- Source of parameter switch: RS485/Bus
- Internal parameter set: Parameter Set 2
- Control mode (P2): Closed loop sensor control
- Min PWM (P2): 5
- Max PWM (P2): 100
- Motor stop enable (P2):
- Controller function (P2): Cooling/Negative
- P-Factor (P2) [%]: 50,19
- I-Factor (P2) [%]: 6,25

At the bottom, there are three buttons: 'Set', 'Set all', and 'Reset'.

Illustration 53: Parameter set 2

Step 4:

Define parameter set 2

- Operation mode: Closed-loop sensor control
- P-Factor: 50%
- I-Factor: 6.25%
- Activate parameter set 2

The screenshot shows the 'Set value' configuration page. On the left, a tree view shows 'Device status' expanded to 'Set value'. The main area contains the following fields:

- Set value [PA]: 450
- Source of set value: RS485/Bus
- Save set value to EEPROM:
- Current sensor value [PA]: 451,94
- Current speed: 643
- Current parameter set: 2
- Active operating mode: Closed loop sensor control
- Source of parameter switch: RS485/Bus
- Current controller function: Cooling/Negative
- Source for controller function: RS485/Bus
- Status: Fan OK

At the bottom, there are three buttons: 'Set', 'Set all', and 'Reset'.

Illustration 54: Digital set value definition for parameter set 1, differential pressure 450 Pa, enter set value Night mode

Step 5:

Defining set values via RS485/Bus

- Set value here: 450 Pa
Night switch
- Set value source: RS485/Bus
- Activate Save set value to EEPROM
- Enter required differential pressure value under Set value to control to constant airflow
- Set value \approx Actual value

4.2.2. Analogue definition of set value with closed-loop airflow control

As another option to the digital definition of set value as given in chapter 4.2.1, it is also possible to define the set value in an analogue way via inputs Ain1 U or Ain1 I. Illustration 55 shows an example of how a potentiometer can be connected to define the set value for the closed-loop airflow control.

Day/Night switching with two different set values is not possible with analogue source for set value. Step 4 and 5 of the example given above do thus not apply to this chapter.

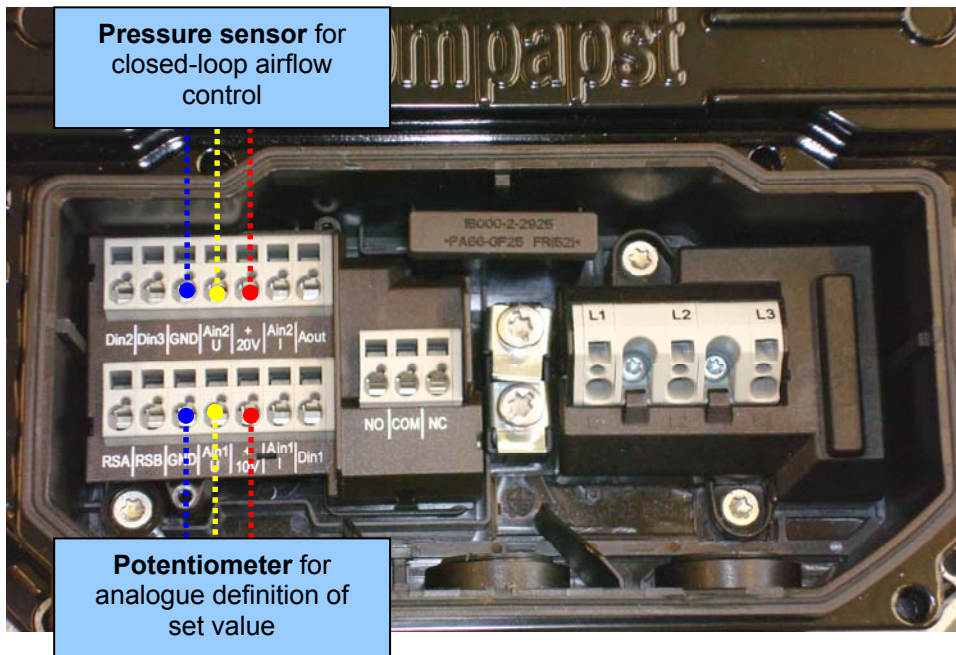
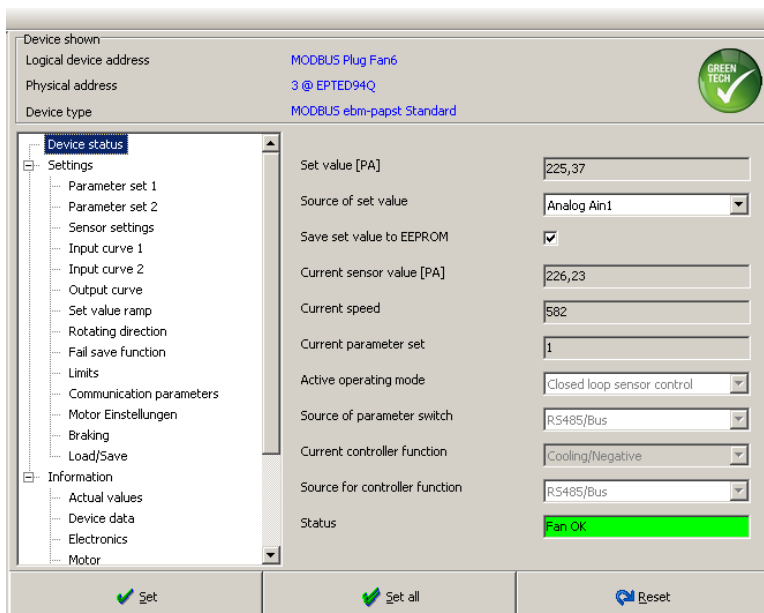

Illustration 55: Analogue definition of set value via potentiometer with closed-loop airflow control

In EC-Control, additional settings have to be defined (in addition to the parameters set in chapter 4.2). For doing this, the set value source has to be changed to *Analogue AIn1* and the function *Save set value to EEPROM* has to be deactivated.



Step 3b:
Analogue definition of set value via AIn1

- Set value source: *Analogue AIn1*
- Deactivate *Save set value to EEPROM*
- Set required differential pressure with external set value source in order to control to constant airflow
- Set value \approx Actual value

Illustration 56: Analogue definition of set value, differential pressure 225 Pa, define set value via potentiometer

4.3. Closed-loop temperature control – Random control curve with temperature sensor

Temperature-controlled systems can be found in many applications. To allow customers to put such a closed-loop control into operation, we will explain how to set the control curve in the following sub-chapters.

To collect the actual value with a temperature sensor and generate an individual control curve from this, a few settings have to be done. The following sensor is used in this example:



- Temperature sensor ebm-papst part no. 50005-1-0174
- Measuring range -20°C to 80°C
- To be connected to:
+20V
Ain2 U
GND

Illustration 57: Standardised temperature sensor, part no. 50005-1-0174

For this temperature sensor, you get the sensor curve given in Illustration 58.

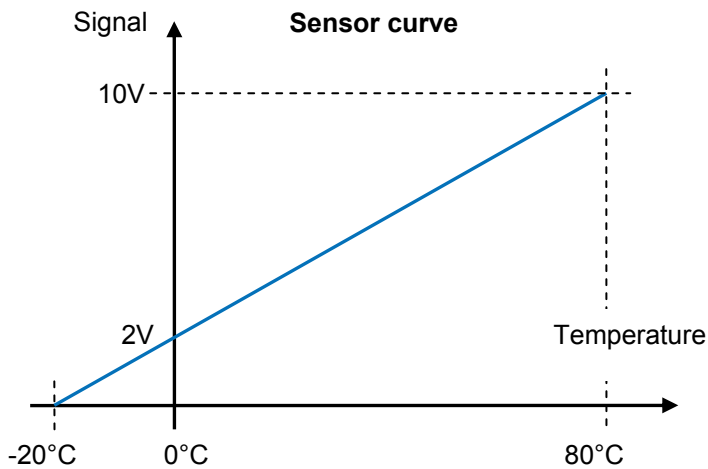

- 0-10V signal from sensor output progresses linearly to measuring range (-20°C to 80°C)

Illustration 58: Sensor curve for temperature sensor

To simplify the setting of the control range for the used, the following formula

$$\text{Control range} = \frac{\text{sensor range}}{P \text{ Factor}} \times 100\%$$

is already integrated in EC-Control, as shown in the comparison in Illustration 59. This is valid whenever the I-factor is 0%.

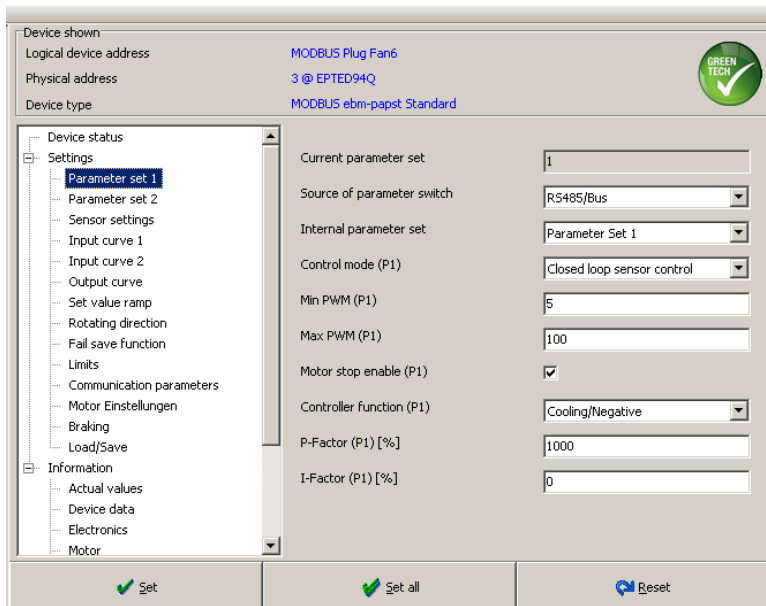

Step 1: Pure P-control

- Operation mode: Closed-loop sensor control
- P-Factor 1000%
- I-Factor 0%
- With closed-loop temperature control pure P-control
- Active direction: Cooling/Negative

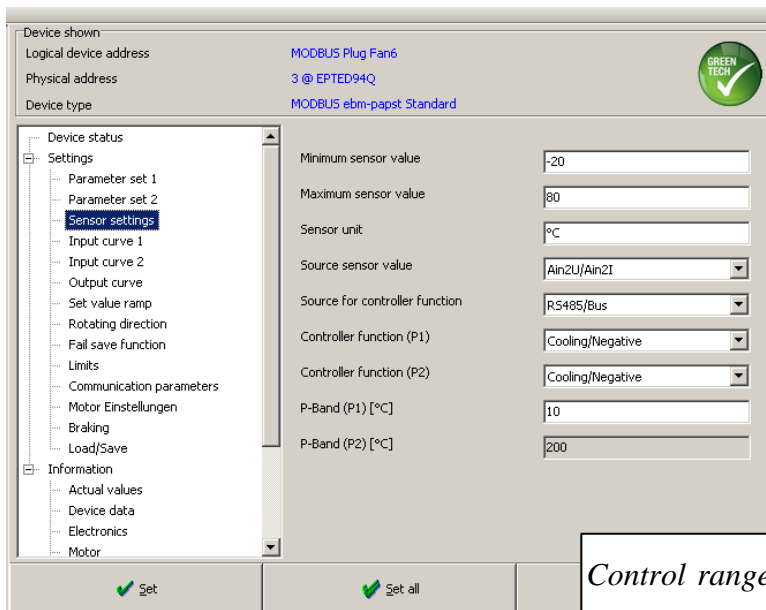

Step 2: Temperature sensor settings

- Sensor range: -20°C to 80°C
- Actual value sensor source: Ain2U/Ain2I
- Source of active direction: RS485/Bus
- Control range P1: 10°C

$$\text{Control range} = \frac{80^{\circ}\text{C} - (-20^{\circ}\text{C})}{1000\%} \times 100\% = 10^{\circ}\text{C}$$

Illustration 59: Control range and P-Factor

The control range respectively the P-Factor can be changed using two selection windows. As the two values depend on each other, entering the P-Factor automatically results in changes to the control range and vice versa. If the I-Factor is bigger than 0%, the input window is displayed in grey (see Illustration 59, control range parameter set 2).

The importance of the control range with a closed-loop temperature control can best be explained in the settings given in our example from Illustration 60.

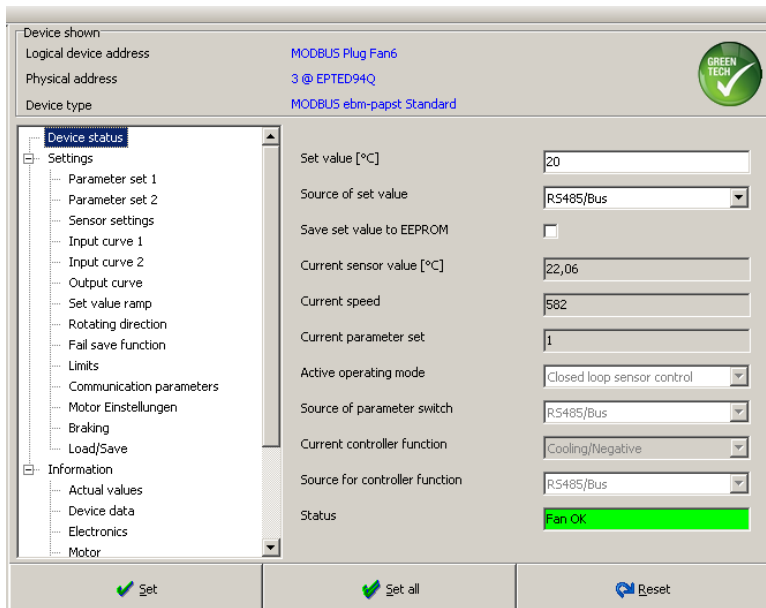

Step 3 (2 examples)
Entering set temperature value

Example 1:

- in [°C]
- Set value: 20
- Actual value: 21.99
- Control difference: 1.99
- Control range: 10

■ Phase control factor thus 20%
And speed 574 rpm

Control difference above:
 $21.99^{\circ}\text{C} - 20.0^{\circ}\text{C} = 1.99^{\circ}\text{C}$

Control difference below:
 $25.02^{\circ}\text{C} - 20.0^{\circ}\text{C} = 5.02^{\circ}\text{C}$

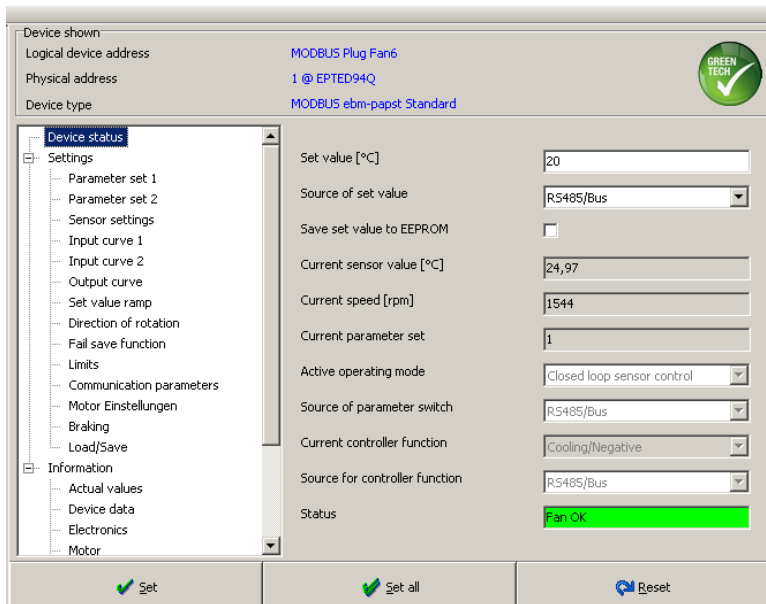

Example 2:

- in [°C]
- Set value: 20
- Actual value: 25.02
- Control difference: 5.02
- Control range: 10

■ Phase control factor thus 50%
And speed 1561 rpm

Illustration 60: Closed-loop temperature control with control difference 2°C and a difference of 5°C

Increasing the control difference increases the phase control factor. With the example given above, the full speed of the motor would be reached as soon as the actual value, i.e. the temperature presently read by the sensor, reached 30°C while the set value still remained 20°C.

Depending on the control range, control curves such as in Illustration. 61 can be generated accordingly. The control range of the example above corresponds with control curve 2. The two control differences, 2°C and 5°C, are given in the diagram as well. If one were to choose a wider control range for the control difference given above, say control curve 4, for instance, the motor would run at very much lower speed with the same actual value for temperature.

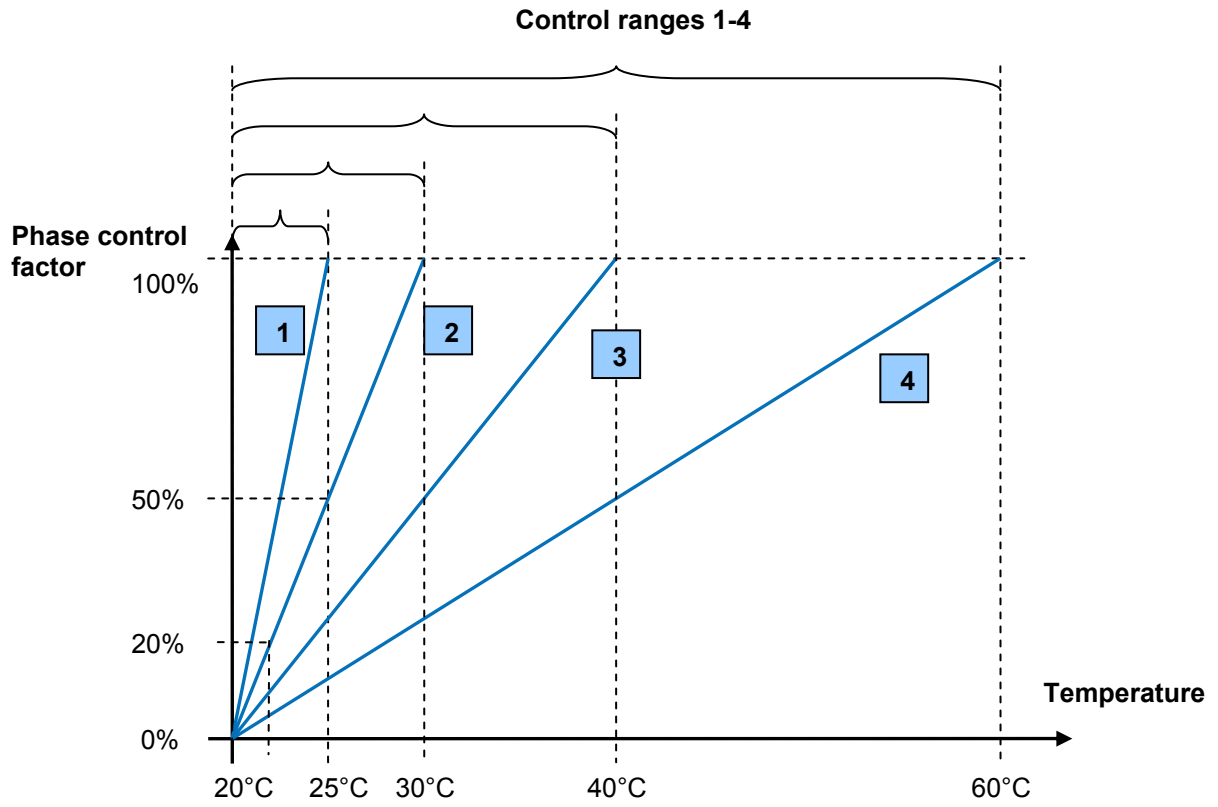

Illustration. 61: Four exemplary open-loop control curves for different closed-loop control ranges

Index

Ain1 I.....	7, 26	Master-Slave	31, 35, 36
Ain1 U.....	7, 26	Max PWM.....	16
Ain2 I.....	7, 24, 34	Min PWM.....	16
Ain2 U.....	7, 24	MODBUS	6, 17
Aout	7, 30	Motor stop enable.....	21
Bridge.....	22	open loop	8
Cascading mode	36	Parameter set.....	22
closed loop.....	8	P-Factor	48
Closed-loop sensor control	13	PWM control.....	13
Closed-loop speed control	13	Regelbereich	50
Closed-loop temperature control	47	Reverse mode.....	38
Common line.....	18	RSA.....	7
Cooling/Negative.....	13	RSB.....	7
D0	7, 18	Save set value to EEPROM	23, 27, 46
D1	7, 18	Sensor.....	34, 47
Day/Night switch	44	sensor range	10
Digital definition of set values.....	43	Set value	26
Din1	7	Setting actual value.....	25
Din2	7, 22, 41	Setting set value.....	43
Din3	7, 22, 41	Setting the set value.....	26
Heating/Positive	14	Start PWM.....	16
I-Faktor.....	12, 47	Terminal strip.....	6, 24
Inverse curves.....	29	Twisted Pair.....	18
Line termination resistors.....	18		