

New generation iQ² with 2 speed, reverse on demand or reverse on start function available.*

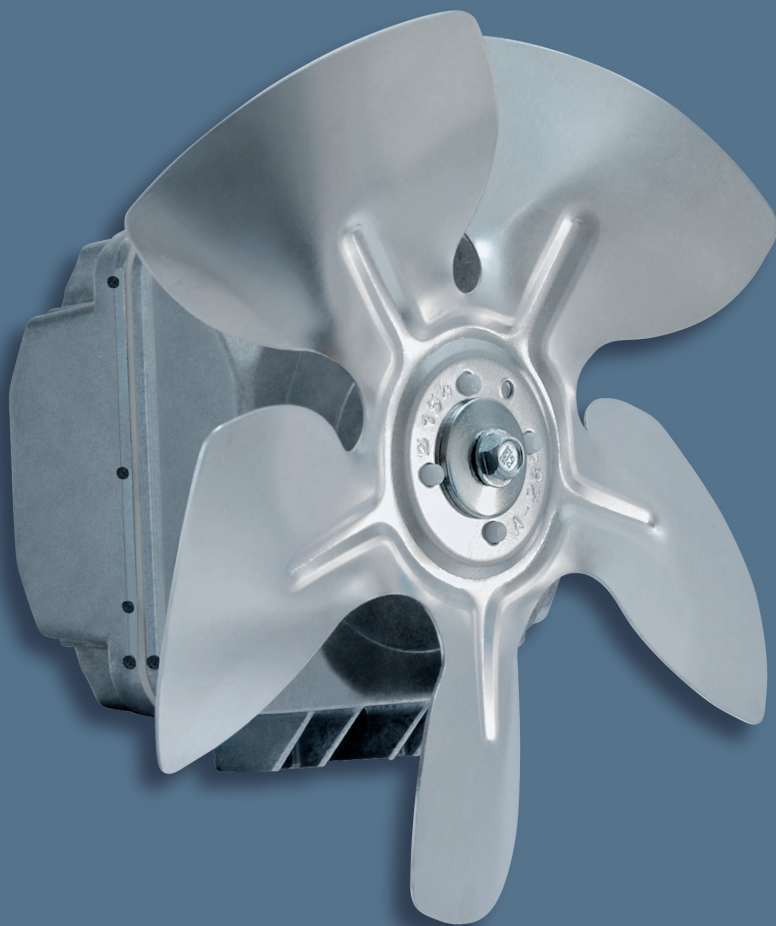

All advantages at a glance

- High efficiency; up to 65%
- Constant speed, even in the event of voltage fluctuations
- Intelligent electronics with overload and locked-rotor protection
- Identical accessories and dimensions to Q-motor
- Long service life due to maintenance-free ball bearings
- iQ3612 to replace 5W, 7W, 10W, 16W Q-motors up to 254mm 28° pitch impeller
- iQ3620 to replace 16W, 18W, 23W, 25W Q-motor up to 300mm 22° pitch impeller

*Ask us for more details

Efficient. Practical. **Intelligent.**

Same on the outside – efficient on the inside!

We have taken a standard Q-motor and a mechanical principle that have been used for decades and made it more efficient. We have made this efficient solution fit the existing application by replicating all possible mounting arrangements with an intelligent motor that will give the air flow required. We have ensured that the motor is protected against moisture to stop premature failure. We have ensured smooth bearing systems to ensure long life times.

Technical data				SAVE					SAVE					SAVE		
Typical iQ-motor (3612) combined with different axial impellers (speed 1,300 rpm)					Air flow	iQ Motor power consumption	Q Motor power consumption	%		Air flow	iQ Motor power consumption	Q Motor power consumption	%		Air flow	iQ Motor power consumption
mm	m ³ /h	W	W	%	m ³ /h	W	W	%	m ³ /h	W	W	%				
Impeller diameter	Blade pitch 22 degrees				Blade pitch 28 degrees				Blade pitch 34 degrees							
154	150	2.4	29	91%	210	2.9	29	90%	235	3.2	32	90%				
172	220	3	29	89%	300	3.8	32	88%	340	5	33	84%				
200	315	3.5	30	88%	440	6	38	84%	515	9.4	42	77%				
230	485	9.5	38	75%	720	15	50	70%	800	24	60	60%				
254	650	15	45	67%	–	–	–	–	–	–	–	–				

* free air flow with wall ring

ebm-papst Part Number	Power Output	Recommended Impellers																		
		154mm			172mm			200mm			230mm			254mm			300mm			
		22°	28°	34°	22°	28°	34°	22°	28°	34°	22°	28°	34°	22°	28°	34°	22°	28°	34°	
iQ3612	Variable	x	x	x	x	x	x	x	x	x	x	x	x	x	x	x				
iQ3620	Variable																x	x	x	x

Multifunction version iQ3612

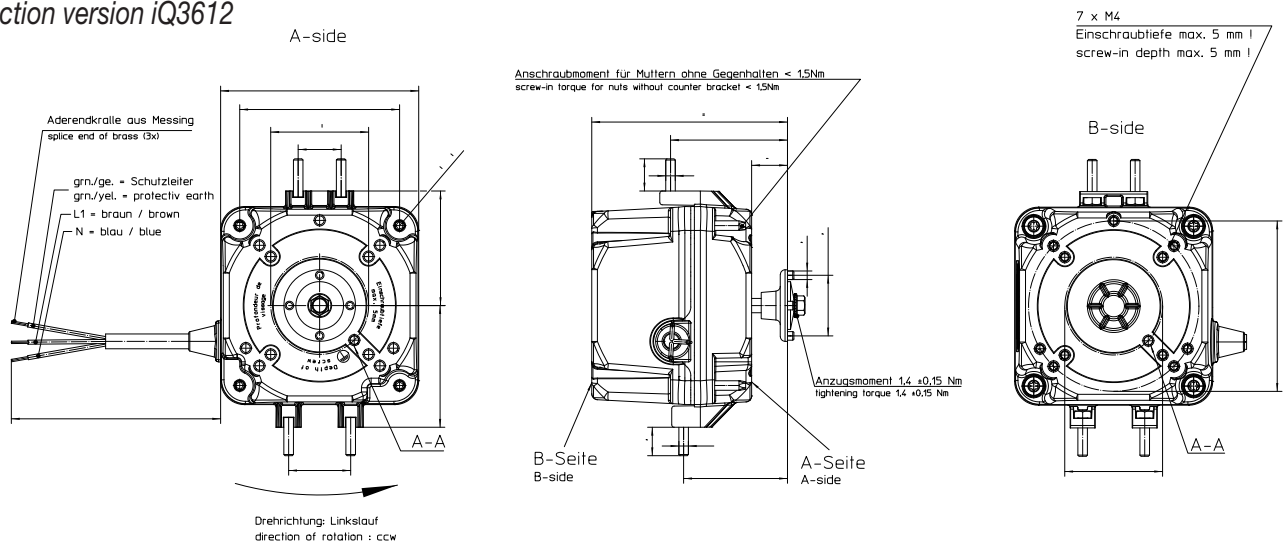

New iQ3620 : please check with us for mounting details

GENERAL OVERVIEW OF IQ-MOTOR DATA

Material: Die-cast aluminum housing
Conveying direction: "V" and "A" (depending on axial impeller used)
Direction of rotation: Anticlockwise, viewing the shaft end
System of protection: IP54; laquered electronics for moisture protection
Insulation class: "F"
Mounting position: Any
Mode of operation: Continuous operation (S1)
Bearings: Maintenance-free ball bearings
Motor protection: Protected by electronics

Temperature: -40°C – +50°C
Electrical connection: Mains cable
Protection class: I (II possible)
Approvals: VDE and UL in progress
Mounting attachment parts: Guard grille and wall ring are attached to the projecting thread ends on the A side
Axial impeller attachment: A plastic adapter with catching peg and M4 screw are used to secure the impeller on the motor shaft

ebm-papst A&NZ Pty Ltd
 AU Tel: +61 3 9360 6400
 NZ Tel: +64 9 837 1884
 email: sales@ebmpapst.com.au

www.ebmpapst.com.au
 www.ebmpapst.co.nz

ebmpapst